





NOTICE OF INCORPORATION

United States Legal Document

 All citizens and residents are hereby advised that this is a legally binding document duly incorporated by reference and that failure to comply with such requirements as hereby detailed within may subject you to criminal or civil penalties under the law. Ignorance of the law shall not excuse noncompliance and it is the responsibility of the citizens to inform themselves as to the laws that are enacted in the United States of America and in the states and cities contained therein. 

* *
*

ANSI A117.1 (1998), Standard for Accessible and Usable Buildings and Facilities as mandated by law and incorporated by reference by the States and Municipalities and in the Code of Federal Regulations at 24 CFR 100.201.

American National Standard

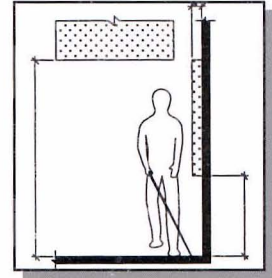

*Accessible and Usable
Buildings and Facilities*

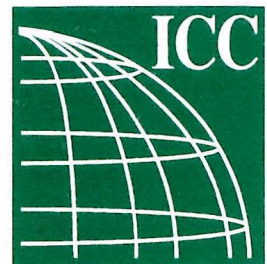

INTERNATIONAL
CODE COUNCIL®

American National Standard

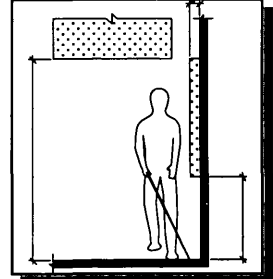
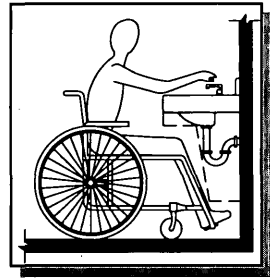

*Accessible and Usable
Buildings and Facilities*



INTERNATIONAL
CODE COUNCIL®

**ICC/ANSI
A117.1-1998**

American National Standard

**Accessible and Usable
Buildings and Facilities**

Secretariat

**International Code Council
5203 Leesburg Pike, Suite 600
Falls Church, VA 22041**

Approved February 13, 1998

**American National Standards Institute, Inc.
25 West 43rd Street - 4th Floor
New York, NY 10036**

Accessible and Usable Buildings and Facilities (ICC/ANSI A117.1-1998)

ISBN 1-58001-029-6

Copyright © 1998



ALL RIGHTS RESERVED. This Accessible and Usable Buildings and Facilities (ICC/ANSI A117.1-1998) is a copyrighted work owned by the International Code Council. Without advance written permission from the copyright owner, no part of this book may be reproduced, distributed or transmitted in any form or by any means, including, without limitation, electronic, optical or mechanical means (by way of example and not limitation, photocopying, or recording by or in an information storage and retrieval system). For information on permission to copy material exceeding fair use, please contact: ICC Publications, 4051 West Flossmoor Road, Country Club Hills, Illinois 60478-5795. (Phone 708-799-2300.)

Trademarks: “International Code Council,” the ICC logo and “Accessible and Usable Buildings and Facilities (ICC/ANSI A117.1-1998)” are trademarks of the International Code Council, Inc.

Printed in the United States of America

First Printing: October 1998

Second Printing: December 1999

Third Printing: April 2001

Fourth Printing: December 2003

Fifth Printing: May 2004

Sixth Printing: April 2005

Seventh Printing: August 2006

American National Standard

Approval of an American National Standard requires verification by ANSI that the requirements for due process, consensus, and other criteria for approval have been met by the standards developer.

Consensus is established when in the judgement of the ANSI Board of Standards Review, substantial agreement has been reached by directly and materially affected interests. Substantial agreement means much more than a simple majority, but not necessarily unanimity. Consensus requires that all views and objections be considered, and that a concerted effort be made toward their resolution.

The use of American National Standards is completely voluntary; their existence does not in any respect preclude anyone, whether he or she has approved the standards or not, from manufacturing, marketing, purchasing, or using products, processes, or procedures not conforming to the standards.

The American National Standards Institute does not develop standards and will in no circumstances give an interpretation of any American National Standard. Moreover, no person shall have the right or authority to issue an interpretation of an American National Standard in the name of the American National Standards Institute. Requests for interpretations should be addressed to the secretariat or sponsor whose name appears on the title page of this standard.

CAUTION NOTICE: This American National Standard may be revised or withdrawn at any time. The procedures of the American National Standards Institute require that action be taken periodically to reaffirm, revise, or withdraw this standard. Purchasers of American National Standards may receive current information on all standards by calling or writing the American National Standards Institute.

FOREWORD

(This Foreword is not part of American National Standard A117.1-1998.)

The 1961 edition of ANSI Standard A117.1 presented the first criteria for accessibility to be approved as an American National Standard and was the result of research conducted by the University of Illinois under a grant from the Easter Seal Research Foundation. The National Easter Seal Society and the President's Committee on Employment of People with Disabilities became members of the Secretariat and the Standard was reaffirmed in 1971.

In 1974, the U.S. Department of Housing and Urban Development joined the Secretariat and sponsored needed research, which resulted in the 1980 edition. After further revision that included a special effort to remove application criteria (scoping requirements), the 1986 edition was published and, when requested in 1987, the Council of American Building Officials (CABO) assumed the Secretariat. Central to the intent of the change in the Secretariat was the development of a standard that, when adopted as part of a building code, would be compatible with the building code and its enforcement. This edition has largely achieved that goal. In 1998, CABO became the International Code Council (ICC).

This edition has been substantially reformatted. Illustrative figures are located adjacent to corresponding text to simplify the use of the Standard. Unless specified otherwise, figures are not part of the Standard. Should a figure appear to illustrate criteria that differ with the text of the Standard, the criteria stated in the text govern.

Suggestions for improving this edition will be welcome. They should be sent to ICC, Secretariat, ANSI A117 Committee, Suite 708, 5203 Leesburg Pike, Falls Church, VA 22041.

This Standard was processed and approved for submittal to ANSI by the Accredited Standards Committee on Architectural Features and Site Design of Public Buildings and Residential Structures for Persons with Handicaps (A117). Committee approval of the Standard does not necessarily imply that all Committee members voted for its approval. At the time it approved this Standard, the A117 Committee had the following members:

Chair Kenneth M. Schoonover, PE (BOCA)
Vice Chair Soy Williams, AIA (PVA)

Organizational Member	Representative
Accessibility Equipment Manufacturers Association	Patrick Bass
American Bankers Association	Nessa Feddis
American Council of the Blind	Julie Carroll Patricia Beattie (Alt)
American Foundation for the Blind	Elga Joffee Scott Marshall (Alt) Alan Dinsmore (Alt)
American Hotel and Motel Association	Robert Elliott
American Institute of Architects	Marvin J. Cantor, FAIA Scott Fazekas, AIA, CBO (Alt)
American Occupational Therapy Association	Mary Shaheen, OTR/L Anne Long Morris, EdD, OTR/L (Alt)
American Society of Interior Designers	Wm. L. Wilkoff, FASID, IIDA Barbara J. Huelat, ASID (Alt)
American Society of Plumbing Engineers	Robert Evans, Jr., CIPE Peter J. Johnson, CIPE (Alt)
American Society of Safety Engineers	William Marletta David A. de Vries (Alt)
Association for Safe and Accessible Products	Edward Steinfeld
Awards and Recognition Association	Kathy Wilson William Townsend (Alt)

Bell Communications Research, Inc	William G. Keenan
Builders Hardware Manufacturers Association, Inc	Dave Gilda Richard Hudnut (Alt)
Building Officials and Code Administrators Intl, Inc	Kenneth M. Schoonover, PE Michael Pfeiffer, PE (Alt)
Building Owners and Managers Association Intl	Lawrence G. Perry, AIA James C. Dinegar (Alt)
Disability Rights Education and Defense Fund	Marilyn Golden Logan Hopper (Alt)
International Code Council	Shahriar Amiri
International Conference of Building Officials	William D. Wall, PE Rick Okawa, PE (Alt)
International Sign Association	Teresa Cox Bob Wallace (Alt) Sharon Toji (Alt)
Little People of America, Inc.	Angela Van Etten, J.D.
National Apartment Association	Ronald G. Nickson
National Association of Home Builders	Jay Murdoch Ron Burton (Alt)
National Association of the Deaf	Don Sievers Nancy J. Bloch (Alt)
National Conference of States on Building Codes and Standards	William E. O'Neil
National Electrical Manufacturers Association	Rein Haus
National Elevator Industry, Inc	Edward A. Donoghue Ralph Droste (Alt) George Kappenhagen (Alt)
National Federation of the Blind	James Gashel Dr. Harold Snider (Alt)
National Fire Protection Association	Ron Coté, PE
National Institute for Tall People	Carlisle Bean
Paralyzed Veterans of America	Kim A. Beasley, AIA Soy Williams (Alt)
Plumbing Manufacturers Institute	Jack Lancaster Richard W. Church (Alt)
President's Committee of Employment of People with Disabilities	Maggie Roffee Ellen D. Daly (Alt)
Self Help for Hard of Hearing People, Inc	Jack O'Keeffe
Society for Environmental Graphic Design	Kenneth A. Ethridge, Jr., AIA
Southern Building Code Congress International, Inc	Mark W. Wales, CBO Richard Vognild, PE, CBO (Alt)
United Cerebral Palsy Associations	Robert Dale Lynch, FAIA Michael Morris (Alt)
US Architectural and Transportation Barriers Compliance Board	Marsha K. Mazz Scott Windley (Alt)
US Department of Agriculture	Larry B. Fleming Samuel Hodges, III (Alt)
US Department of Housing and Urban Development	Nelson A. Carbonell Cheryl D. Kent (Alt) Alan Rothman (Alt)
US Department of Veterans Affairs	Dennis Hancher
World Institute on Disability	Hale Zukas

Individual Members

Brian D. Black

Patrick J. Higgins

Jake L. Pauls

Special recognition is provided to the following individuals who also contributed as members of the committee during this review cycle:

Richard Hudnut (Chair 1987–1997)

Frank Bosak (Vice-Chair 1987–1997)

John P. S. Salmen

Contents

Chapter 1. Application and Administration	1
101 Purpose	1
102 Provisions for Adults	1
103 Compliance Alternatives	1
104 Conventions	1
105 Referenced American National Standards	1
106 Definitions	1
Chapter 2. Scoping	5
201 General	5
202 Dwelling Units	5
203 Administration	5
Chapter 3. Building Blocks	7
301 General	7
302 Floor or Ground Surfaces	7
303 Changes in Level	7
304 Wheelchair Turning Space	8
305 Clear Floor or Ground Space	8
306 Knee and Toe Clearance	9
307 Protruding Objects	10
308 Reach Ranges	11
309 Operable Parts	12
Chapter 4. Accessible Routes	13
401 General	13
402 Accessible Routes	13
403 Walking Surfaces	13
404 Doors and Doorways	14
405 Ramps	18
406 Curb Ramps	20
407 Elevators	21
408 Wheelchair (Platform) Lifts	31
Chapter 5. General Site and Building Elements	33
501 General	33
502 Parking Spaces	33
503 Passenger Loading Zones	33
504 Stairways	34
505 Handrails	35
506 Windows	38
507 Bus Stop Pads	38
Chapter 6. Plumbing Elements and Facilities	39
601 General	39
602 Drinking Fountains and Water Coolers	39
603 Toilet and Bathing Rooms	39
604 Water Closets and Toilet Compartments	40
605 Urinals	43
606 Lavatories and Sinks	43
607 Bathtubs	44
608 Shower Compartments	45
609 Grab Bars	47
610 Seats	49
611 Laundry Equipment	50

Chapter 7. Communication Elements and Features	51
701 General	51
702 Alarms	51
703 Signs	56
704 Telephones	60
705 Detectable Warnings	61
706 Assistive Listening Systems	62
707 Automatic Teller Machines (ATMs) and Fare Machines	62
Chapter 8. Special Rooms and Spaces	65
801 General	65
802 Auditorium and Assembly Areas	65
803 Dressing, Fitting, and Locker Rooms	66
804 Kitchens	66
Chapter 9. Built-In Furnishings and Equipment	67
901 General	67
902 Seating at Tables, Counters, and Work Surfaces	67
903 Benches	67
904 Checkout and Service Counters	67
905 Storage Facilities	68
Chapter 10. Dwelling Units	69
1001 General	69
1002 Type A Dwelling Units	69
1003 Type B Dwelling Units	74
1004 Dwelling Units with Accessible Communication Features	78
1992-1998 ANSI A117.1 Cross Reference	79
Errata to ICC/ANSI A117.1-1998, First Printing, Second Printing, Third Printing .	83

List of Figures

Chapter 1. Application and Administration	1
Figure 104.2 Graphic Convention for Figures	2
Chapter 2. Scoping (No figures)	5
Chapter 3. Building Blocks	7
Figure 302.2 Carpet on Floor or Ground Surfaces	7
Figure 302.3 Openings in Floor or Ground Surfaces	7
Figure 303.2 Vertical Changes in Level	7
Figure 303.3 Beveled Changes in Level	7
Figure 304.3 Size of Wheelchair Turning Space	8
Figure 305.5 Position of Clear Floor or Ground Space	8
Figure 305.7 Maneuvering Clearance in an Alcove	9
Figure 306.2 Toe Clearance	9
Figure 306.3 Knee Clearance	10
Figure 307.2 Limits of Protruding Objects	10
Figure 307.3 Post-Mounted Protruding Objects	10
Figure 307.4 Reduced Vertical Clearance	11
Figure 308.2.1 Unobstructed Forward Reach	11
Figure 308.2.2 Obstructed High Forward Reach	11
Figure 308.3.1 Unobstructed Side Reach	12
Figure 308.3.2 Obstructed High Side Reach	12
Chapter 4. Accessible Routes	13
Figure 403.5 Clear Width of an Accessible Route	13
Figure 403.5.1 Clear Width at Turn	14
Figure 404.2.3 Clear Width of Doorways	14
Figure 404.2.4.1 Maneuvering Clearance at Swinging Doors	15
Figure 404.2.4.2 Maneuvering Clearance at Sliding and Folding Doors	17
Figure 404.2.6 Two Doors in Series	17
Figure 405.7 Ramp Landings	19
Figure 405.9 Ramp Edge Protection	20
Figure 406.3 Counter Slope of Surfaces Adjacent to Curb Ramps	20
Figure 406.4 Sides of Curb Ramps	21
Figure 406.11 Diagonal Curb Ramps	21
Figure 406.12 Islands	22
Figure 407.2.2 Elevator Call Buttons	22
Figure 407.2.3.2.1 Height of Elevator Visible Signals	22
Figure 407.2.3.2.2 Size of Elevator Visible Signals	23
Figure 407.2.4 Tactile Characters on Elevator Hoistway Entrances	23
Figure 407.2.8 Inside Dimensions of Elevator Cars	24
Figure 407.2.11.1 Elevator Car Control Buttons	25
Figure 407.3.5 Destination-Oriented Elevator Car Identification	28
Figure 407.4.6 Inside Dimensions of Limited Use/Limited Application (LULA) Elevator Cars	29
Figure 407.5.5 Existing Car Configurations	31
Figure 407.5.6.1 Elevator Car Control Buttons in Existing Elevators	31
Chapter 5. General Site and Building Elements	33
Figure 502.2 Vehicle Parking Space	33
Figure 502.3 Parking Space Access Aisle	34
Figure 503.3 Passenger Loading Zone Access Aisle	34
Figure 504.2 Treads and Risers for Accessible Stairways	34
Figure 504.5 Stair Nosings	35
Figure 505.4 Handrail Height	36
Figure 505.5 Handrail Clearance	36
Figure 505.7 Handrail Cross Section	36
Figure 505.10.1 Top and Bottom Handrail Extensions at Ramps	37

Figure 505.10.2	Top Handrail Extensions at Stairs	37
Figure 505.10.3	Bottom Handrail Extensions at Stairs	37
Chapter 6. Plumbing Elements and Facilities		39
Figure 602.5	Drinking Fountain Spout Location	39
Figure 604.2	Water Closet Location	40
Figure 604.3.1	Size of Clearance for Water Closet	40
Figure 604.4	Height of Water Closet	40
Figure 604.5.1	Side Wall Grab Bar for Water Closet	41
Figure 604.5.2	Rear Wall Grab Bar for Water Closet	41
Figure 604.7	Dispenser Location	41
Figure 604.8.1.1	Wheelchair Accessible Toilet Compartments	42
Figure 604.8.1.4	Toilet Compartment Toe Clearance	42
Figure 604.8.3	Toilet Compartment Doors	43
Figure 606.3	Height of Lavatories and Sinks	44
Figure 607.2	Clearance for Bathtubs	44
Figure 607.4.1	Grab Bars for Bathtubs with Permanent Seats	45
Figure 607.4.2	Grab Bars for Bathtubs without Permanent Seats	45
Figure 607.5	Location of Bathtub Controls	45
Figure 608.2.1	Transfer-Type Shower Compartment	46
Figure 608.2.2	Standard Roll-In-Type Shower Compartment	46
Figure 608.2.3	Alternate Roll-In-Type Shower Compartment	46
Figure 608.3.1	Grab Bars in Transfer-Type Showers	46
Figure 608.3.2	Grab Bars in Roll-In-Type Showers	47
Figure 608.5	Controls in Transfer-Type Showers	48
Figure 608.6	Location of Shower Spray Unit	48
Figure 609.2	Size of Grab Bars	48
Figure 609.3	Spacing of Grab Bars	48
Figure 610.2	Bathtub Seat	49
Figure 610.3.1	Rectangular Shower Compartment Seat	50
Figure 610.3.2	L-Shaped Shower Compartment Seat	50
Figure 611.4	Height of Laundry Equipment	50
Chapter 7. Communication Elements and Features		51
Figure 702.3.3.1	Location of Wall-Mounted Appliances	51
Figure 702.3.3.2	Location of Ceiling-Mounted Appliances	52
Figure 702.3.5.1	Appliance Spacing in Corridors	53
Figure 702.3.6.2	Appliance Location in Sleeping Rooms	53
Figure 703.2.4.4	Character Height	56
Figure 703.2.8	Mounting Location at Doors	57
Figure 703.6.1	Pictogram Field	59
Figure 703.7.2.1	International Symbol of Accessibility	60
Figure 703.7.2.2	International TTY Symbol	60
Figure 703.7.2.3	Volume-Controlled Telephone	60
Figure 703.7.2.4	International Symbol of Access for Hearing Loss	60
Figure 704.2.1	Clear Floor or Ground Space for Telephones	60
Figure 705.3.1.1	Truncated Dome Size	61
Chapter 8. Special Rooms and Spaces		65
Figure 802.3	Width of a Wheelchair Space in Auditorium and Assembly Areas	65
Figure 802.4	Depth of a Wheelchair Space in Auditorium and Assembly Areas	65
Chapter 9. Built-In Furnishings and Equipment		67
Figure 904.2	Height of Checkout Counters	67
Chapter 10. Dwelling Units		69
Figure 1002.7.7.3	Location of Controls in Private Residence Elevators	70
Figure 1002.11.5.1	Location of Water Closet in Type A Dwelling Units	71
Figure 1002.11.5.2	Water Closet Clearance in Type A Dwelling Units	71
Figure 1002.12.3	Work Surface in Kitchen	73
Figure 1002.12.4	Kitchen Sink	73

Chapter 1. Application and Administration

101 Purpose

The specifications in Chapters 3 through 9, and Sections 1002 and 1004 of this standard make sites, facilities, buildings and elements accessible to and usable by people with such physical disabilities as the inability to walk, difficulty walking, reliance on walking aids, blindness and visual impairment, deafness and hearing impairment, incoordination, reaching and manipulation disabilities, lack of stamina, difficulty interpreting and reacting to sensory information, and extremes of physical size. The intent of these sections of the standard is to allow a person with a physical disability to independently get to, enter, and use a site, facility, building, or element.

Section 1003 of this standard provides technical criteria for Type B dwelling units. These criteria are intended to be consistent with the intent of only the technical requirements of the Federal Fair Housing Act Accessibility Guidelines. These Type B dwelling units are intended to supplement, not replace, accessible Type A dwelling units as specified in this standard.

This standard is intended for adoption by government agencies and by organizations setting model codes to achieve uniformity in the technical design criteria in building codes and other regulations.

101.1 Applicability. Sites, facilities, buildings, and elements required to be accessible shall comply with the applicable provisions of Chapters 3 through 9.

EXCEPTIONS:

1. Type A dwelling units shall comply with Section 1002.
2. Type B dwelling units shall comply with Section 1003.
3. Dwelling units required to have accessible communication features shall comply with Section 1004.

102 Provisions for Adults

The specifications in this standard are based on adult dimensions and anthropometrics.

103 Compliance Alternatives

Nothing in this standard is intended to prevent the use of designs, products, or technologies as alternatives to those prescribed by this standard, where equivalent or superior accessibility and usability are provided and such equivalency is approved by the administrative authority adopting this standard.

104 Conventions

104.1 Dimensions. Dimensions that are not stated as "maximum" or "minimum" are absolute. All dimensions are subject to conventional industry tolerances.

104.2 Graphics. Unless specifically stated otherwise, figures included herein are not considered part of the standard and are provided for informational purposes only.

105 Referenced American National Standards

105.1 General. The American National Standards listed in Section 105.2 are referenced in this document. Where requirements in this standard differ from those of these referenced standards, the requirements of this standard shall apply.

105.2 Referenced Standards.

105.2.1 Power Operated Pedestrian Doors. ANSI/BHMA A156.10-1991.

105.2.2 Power Assist and Low Energy Power Operated Doors. ANSI/BHMA A156.19-1997.

105.2.3 Safety Code for Elevators and Escalators. ASME/ANSI A17.1-1996.

105.2.4 Audible Emergency Evacuation Signal. ANSI S3.41-1990.

105.2.5 Installation, Maintenance, and Use of Protective Signaling Systems. NFPA 72-1996.

106 Definitions

106.1 General. For the purpose of this standard, the terms listed in Section 106.5 have the indicated meaning.





Convention	Description
	dimension showing English units (in inches unless otherwise specified) above the line and SI units (in millimeters unless otherwise specified) below the line
	dimension for small measurements
min	minimum
max	maximum
	boundary of clear floor space or maneuvering clearance
	centerline
	a permitted element or its extension
	direction of travel or approach
	a wall, floor, ceiling, or other element cut in section or plan
	an element in elevation or plan
	location zone of element, control, or feature

Fig. 104.2
Graphic Convention for Figures

106.2 Terms Defined in Referenced Standards. Terms not defined in this section, but specifically defined in a referenced standard, shall have the specified meaning from the referenced standard, unless otherwise stated.

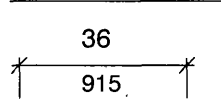
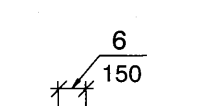
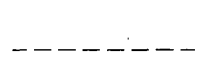
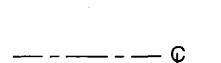
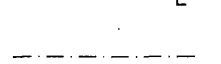
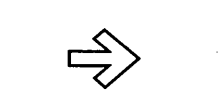
106.3 Undefined Terms. The meaning of terms not specifically defined in this document or in referenced standards shall be as defined by collegiate dictionaries in the sense that the context implies.

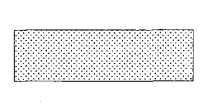
106.4 Interchangeability. Words, terms, and phrases used in the singular includes the plural and the plural the singular.

106.5 Defined Terms.

access aisle: An accessible pedestrian space between elements such as parking spaces, seating, and desks, that provides clearances appropriate for use of the elements.

accessible: Describes a site, building, facility, or portion thereof that complies with this standard.

accessible route: An interior or exterior circulation path that complies with this standard.

administrative authority: A jurisdictional body that adopts or enforces regulations and standards for the design, construction, or operation of buildings and facilities.

automatic door: A door operated with power mechanisms and controls.

Braille: A system which translates text into cells formed by raised dots.

characters: Letters, numbers, punctuation marks, and typographic symbols.

circulation path: An exterior or interior way of passage from one place to another for pedestrians.

counter slope: Any slope opposing the running slope of a curb ramp or ramp.

cross slope: The slope that is perpendicular to the direction of travel (see running slope).

curb ramp: A short ramp cutting through a curb or built up to it.

destination-oriented elevator system: An elevator system that provides lobby controls to select destination floors, lobby indicators designating which elevator to board, and a car indicator designating the floors at which the car will stop.

element: An architectural or mechanical component of a building, facility, space, or site.

facility: All or any portion of a building, structure, or area, including the site on which such building, structure, or area is located, wherein specific services are provided or activities are performed.

key surface: The surface or plane of any key or button which must be touched to activate or deactivate an operable part or a machine function or enter data.

marked crossing: A crosswalk or other identified path intended for pedestrian use in crossing a vehicular way.

operable part: A component of an element used to insert or withdraw objects, or to activate, deactivate, or adjust the element.

pictogram: A pictorial symbol which is recognized as representing activities, facilities, or concepts.

power-assisted door: A door used for human passage, with a mechanism that helps to open the door, or to relieve the opening resistance of the door.

ramp: A walking surface that has a running slope steeper than 1:20.

running slope: The slope that is parallel to the direction of travel (see cross slope).

sign: An architectural element composed of displayed textual, symbolic, tactile, or pictorial information.

site: A parcel of land bounded by a property line or a designated portion of a public right-of-way.

tactile: Describes an object that can be perceived using the sense of touch.

TTY: Machinery or equipment that employs interactive, graphic communications through the transmission of coded signals across the standard telephone network. The term TTY also refers to devices known as text telephones and TDDs.

vehicular way: A route provided for vehicular traffic.

walk: An exterior pathway with a prepared surface for pedestrian use.

Chapter 2. Scoping

201 General

This standard provides technical criteria for making sites, facilities, buildings, and elements accessible. The administrative authority shall provide scoping provisions to specify the extent to which these technical criteria apply. These scoping provisions shall address the application of the standard to: each building and occupancy type; new construction, alterations, temporary facilities, and existing buildings; specific site and building elements; and to multiple elements or spaces provided within a site or building.

202 Dwelling Units

Chapter 10 of this standard contains technical criteria for Type A dwelling units, Type B dwelling units, and dwelling units with accessible communication features. The administrative authority shall specify, in separate scoping provisions, the extent to which these technical criteria apply. These scoping provisions shall address the types and numbers of dwelling units required to comply with each set of dwelling unit criteria.

203 Administration

The administrative authority shall provide an appropriate review and approval process to ensure compliance with this standard.

Chapter 3. Building Blocks

301 General

301.1 Scope. The provisions of this chapter shall apply where required by the scoping provisions adopted by the administrative authority or by Chapters 4 through 10.

302 Floor or Ground Surfaces

302.1 General. Floor or ground surfaces shall be stable, firm, and slip resistant, and shall comply with Section 302. Changes in level in floor or ground surfaces shall comply with Section 303.

302.2 Carpet. Carpet or carpet tile shall be securely attached and shall have a firm cushion, pad, or backing or no cushion or pad. Carpet or carpet tile shall have a level loop, textured loop, level cut pile, or level cut/uncut pile texture. Pile height shall be $\frac{1}{2}$ inch (13 mm) maximum. Exposed edges of carpet shall be fastened to floor or ground surfaces and shall have trim along the entire length of the exposed edge. Carpet edge trim shall comply with Section 303.

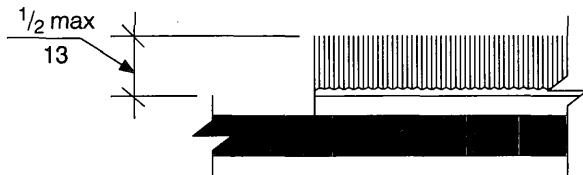

Fig. 302.2
Carpet on Floor or Ground Surfaces

302.3 Openings. Openings in floor or ground surfaces shall be of a size that does not permit the passage of a $\frac{1}{2}$ inch (13 mm) diameter sphere, except as allowed in Sections 407 and 408. Elongated openings shall be placed so that the long dimension is perpendicular to the dominant direction of travel.

303 Changes in Level

303.1 General. Changes in level in floor or ground surfaces shall comply with Section 303.

303.2 Vertical. Changes in level of $\frac{1}{4}$ inch (6.4 mm) high maximum shall be permitted to be vertical.

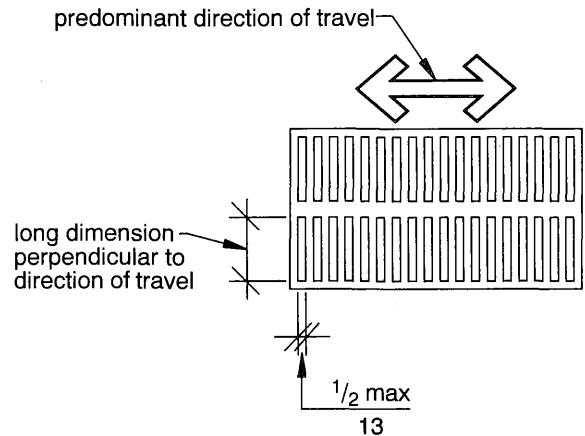

Fig. 302.3
Openings in Floor or Ground Surfaces

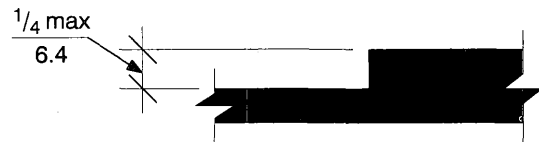

Fig. 303.2
Vertical Changes in Level

303.3 Beveled. Changes in level between $\frac{1}{4}$ inch (6.4 mm) high minimum and $\frac{1}{2}$ inch (13 mm) high maximum shall be beveled with a slope not steeper than 1:2.

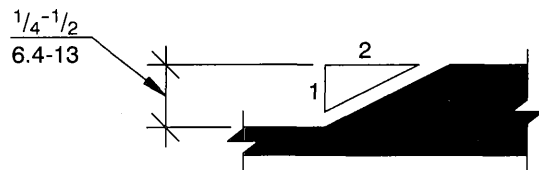

Fig. 303.3
Beveled Changes in Level

303.4 Ramped. Changes in level greater than $\frac{1}{2}$ inch (13 mm) shall be ramped and shall comply with Section 405 or 406.

304 Wheelchair Turning Space

304.1 General. A wheelchair turning space shall comply with Section 304.

304.2 Floor or Ground Surface. Floor or ground surfaces of a wheelchair turning space shall have a slope not steeper than 1:48 and shall comply with Section 302.

304.3 Size. Wheelchair turning space shall comply with Section 304.3.1 or 304.3.2.

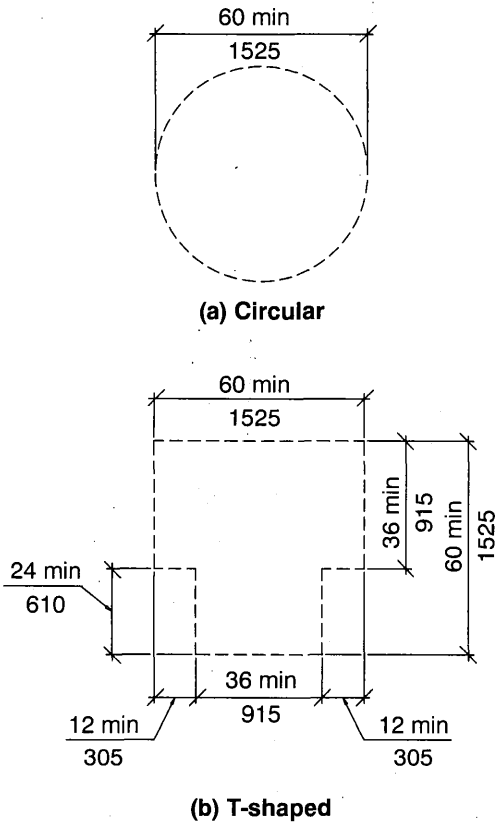

Fig. 304.3
Size of Wheelchair Turning Space

304.3.1 Circular Space. The wheelchair turning space shall be not less than 60 inches (1525 mm) diameter minimum. Wheelchair turning space shall be permitted to include knee and toe clearance complying with Section 306.

304.3.2 T-Shaped Space. The wheelchair turning space shall be a T-shaped space within a 60 inch (1525 mm) minimum square with arms and base 36 inches (915 mm) wide minimum. Each arm of the T shall be clear of obstructions 12 inches (305 mm) minimum in each direction and the base shall be clear of obstructions 24 inches (610 mm) minimum. T-shaped wheelchair turning spaces shall be permitted to in-

clude knee and toe clearance complying with Section 306 only at the end of either the base or one arm.

304.4 Doors. Unless otherwise specified, doors shall be permitted to swing into wheelchair turning spaces.

305 Clear Floor or Ground Space

305.1 General. Clear floor or ground space shall comply with Section 305.

305.2 Floor or Ground Surfaces. Floor or ground surfaces of a clear floor or ground space shall have a slope not steeper than 1:48 and shall comply with Section 302.

305.3 Size. The clear floor or ground space shall be 30 inches (760 mm) minimum by 48 inches (1220 mm) minimum.

305.4 Knee and Toe Clearance. Unless otherwise specified, clear floor or ground space shall be permitted to include knee and toe clearance complying with Section 306.

305.5 Position. Unless otherwise specified, the clear floor or ground space shall be positioned for either forward or parallel approach to an element.

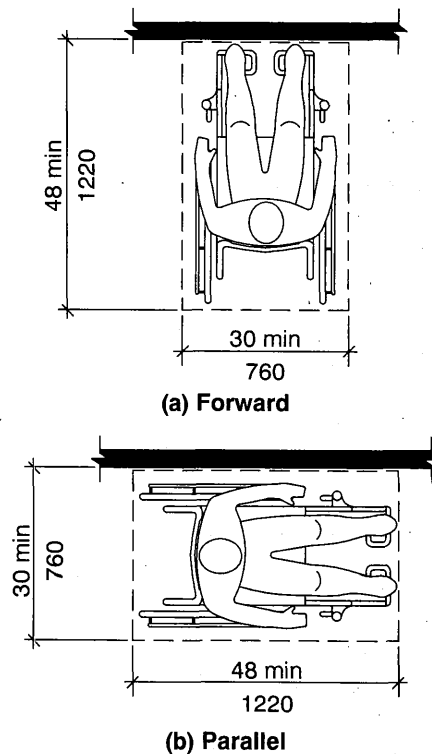

Fig. 305.5
Position of Clear Floor or Ground Space

305.6 Approach. One full unobstructed side of the clear floor or ground space shall adjoin or overlap an accessible route or adjoin another clear floor or ground space.

305.7 Maneuvering Clearance. If a clear floor or ground space is in an alcove or otherwise confined on all or part of three sides, additional maneuvering clearances complying with Sections 305.7.1 and 305.7.2 shall be provided.

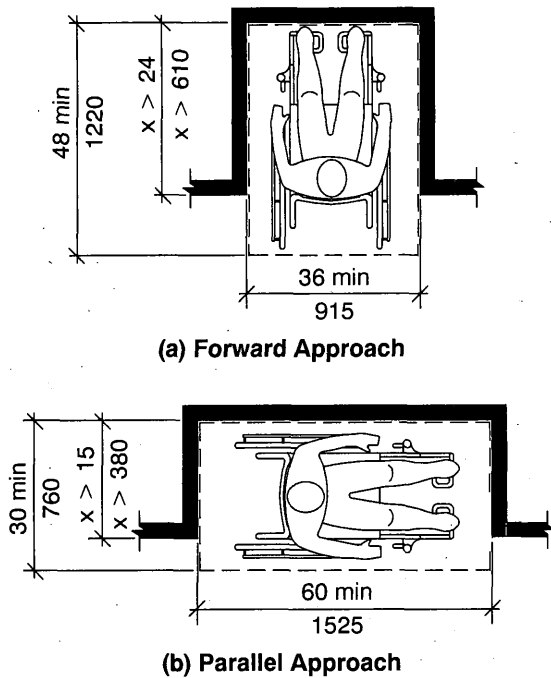

Fig. 305.7
Maneuvering Clearance in an Alcove

305.7.1 Forward Approach. The width of an alcove shall be 36 inches (915 mm) minimum where the depth exceeds 24 inches (610 mm).

305.7.2 Parallel Approach. The width of an alcove shall be 60 inches (1525 mm) minimum where the depth exceeds 15 inches (380 mm).

306 Knee and Toe Clearance

306.1 General. Where space beneath an element is included as part of clear floor or ground space at an element, clearance at an element, or a wheelchair turning space, the space shall comply with Section 306. Additional space beyond knee and toe clearance shall be permitted beneath elements.

306.2 Toe Clearance.

306.2.1 General. Space under an element between the floor or ground and 9 inches (230

mm) above the floor or ground shall be toe clearance and shall comply with Section 306.2.

306.2.2 Maximum Depth. Toe clearance shall be permitted to extend 25 inches (635 mm) maximum under an element.

306.2.3 Minimum Depth. Where toe clearance is required at an element as part of a clear floor or ground space, the toe clearance shall extend 17 inches (430 mm) minimum beneath the element.

306.2.4 Additional Clearance. Space extending greater than 6 inches (150 mm) beyond the available knee clearance at 9 inches (230 mm) above the floor or ground shall not be included in toe clearance.

306.2.5 Width. Toe clearance shall be 30 inches (760 mm) wide minimum.

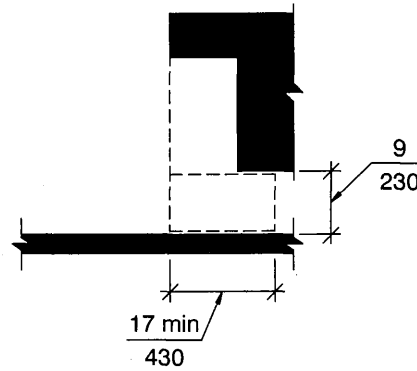

Fig. 306.2
Toe Clearance

306.3 Knee Clearance.

306.3.1 General. Space under an element between 9 inches (230 mm) and 27 inches (685 mm) above the floor or ground shall be knee clearance and shall comply with Section 306.3.

306.3.2 Maximum Depth. Knee clearance shall be permitted to extend 25 inches (635 mm) maximum under an element at 9 inches (230 mm) above the floor or ground.

306.3.3 Minimum Depth. Where knee clearance is required beneath an element as part of a clear floor or ground space, the knee clearance shall be 11 inches (280 mm) deep minimum at 9 inches (230 mm) above the floor or ground, and 8 inches (205 mm) deep minimum at 27 inches (685 mm) above the floor or ground.

306.3.4 Clearance Reduction. Between 9 inches (230 mm) and 27 inches (685 mm) above

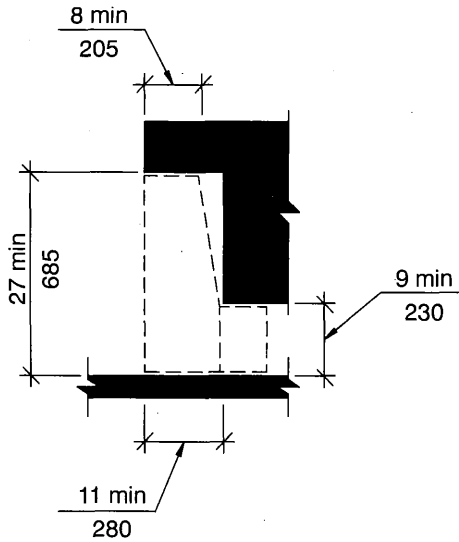

Fig. 306.3
Knee Clearance

the floor or ground, the knee clearance shall be permitted to be reduced at a rate of 1 inch (26 mm) for each 6 inches (150 mm) in height.

306.3.5 Width. Knee clearance shall be 30 inches (760 mm) wide minimum.

307 Protruding Objects

307.1 General. Protruding objects on circulation paths shall comply with Section 307.

307.2 Protrusion Limits. Objects with leading edges more than 27 inches (685 mm) and not more than 80 inches (2030 mm) above the floor or ground shall protrude 4 inches (102 mm) maximum horizontally into the circulation path.

EXCEPTION: Handrails serving stairs and ramps shall be permitted to protrude 4 1/2 inches (115 mm) maximum.

307.3 Post-Mounted Objects. Objects on a single post or pylon shall be permitted to overhang 12 inches (305 mm) maximum where more than 27 inches (685 mm) and not more than 80 inches (2030 mm) above the floor or ground. Objects on multiple posts or pylons where the clear distance between the posts or pylons is greater than 12 inches (305 mm), shall have the lowest edge of such object either 27 inches (685 mm) maximum or 80 inches (2030 mm) minimum above the floor or ground surface.

EXCEPTION: Sloping portions of handrails serving stairs and ramps.

307.4 Reduced Vertical Clearance. Guardrails or other barriers shall be provided where vertical

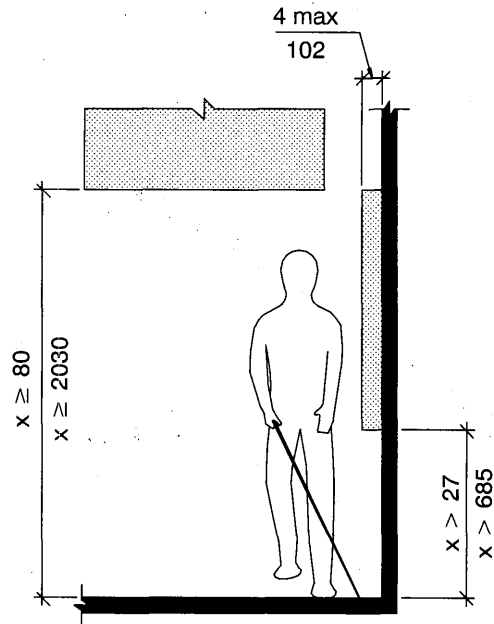
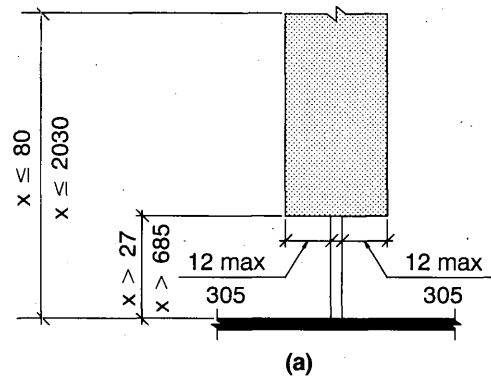
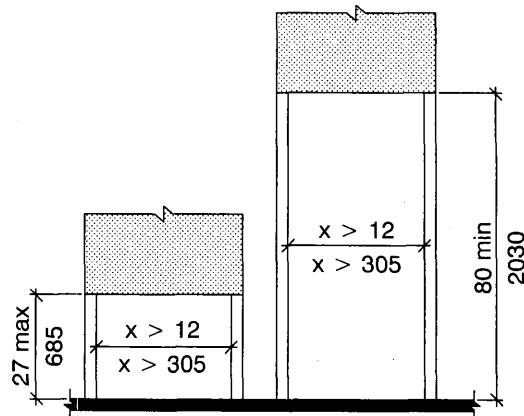

Fig. 307.2
Limits of Protruding Objects



(a)



(b)

Fig. 307.3
Post-Mounted Protruding Objects

clearance is less than 80 inches (2030 mm) high. Leading edge of such guardrail or barrier shall be 27 inches (685 mm) maximum above the floor or ground.

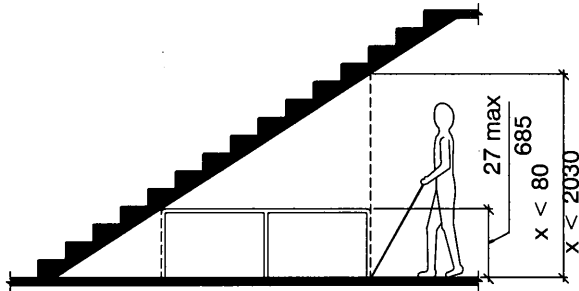

Fig. 307.4
Reduced Vertical Clearance

307.5 Required Clear Width. Protruding objects shall not reduce the clear width required for accessible routes.

308 Reach Ranges

308.1 General. Reach ranges shall comply with Section 308.

308.2 Forward Reach.

308.2.1 Unobstructed. Where a forward reach is unobstructed, the high forward reach shall be 48 inches (1220 mm) maximum and the low forward reach shall be 15 inches (380 mm) minimum above the floor or ground.

308.2.2 Obstructed High Reach. Where a high forward reach is over an obstruction, the

clear floor or ground space shall extend beneath the element for a distance not less than the required reach depth over the obstruction. The high forward reach shall be 48 inches (1220 mm) maximum where the reach depth is 20 inches (510 mm) maximum. Where the reach depth exceeds 20 inches (510 mm), the high forward reach shall be 44 inches (1120 mm) maximum and the reach depth shall be 25 inches (635 mm) maximum.

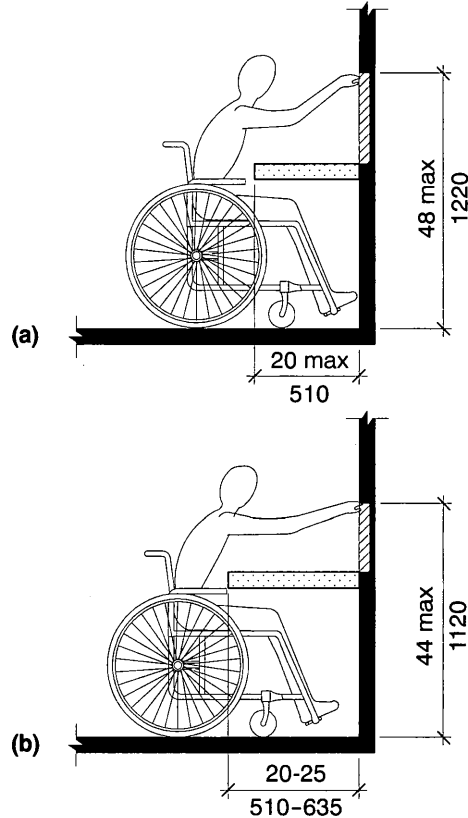

Fig. 308.2.2
Obstructed High Forward Reach

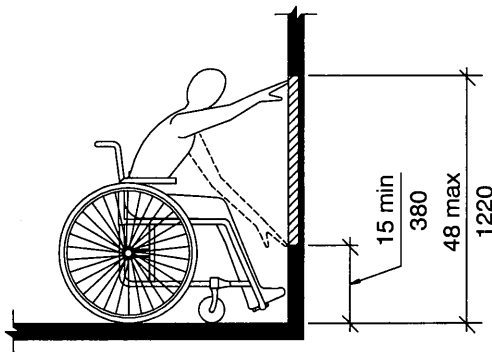

Fig. 308.2.1
Unobstructed Forward Reach

308.3 Side Reach.

308.3.1 Unobstructed. Where a clear floor or ground space allows a parallel approach to an element and the side reach is unobstructed, the high side reach shall be 48 inches (1220 mm) maximum and the low side reach shall be 15 inches (380 mm) minimum above the floor or ground.

EXCEPTION: Existing elements shall be permitted at 54 inches (1370 mm) maximum above the floor or ground.

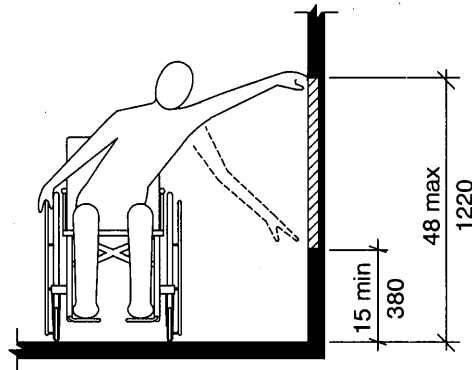

Fig. 308.3.1
Unobstructed Side Reach

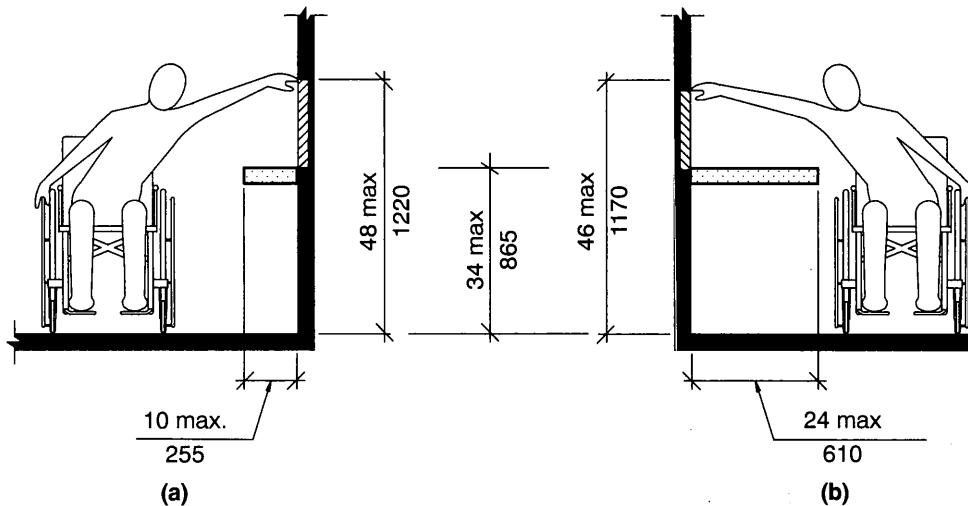

Fig. 308.3.2
Obstructed High Side Reach

308.3.2 Obstructed High Reach. Where a clear floor or ground space allows a parallel approach to an object and the high side reach is over an obstruction, the height of the obstruction shall be 34 inches (865 mm) maximum and the depth of the obstruction shall be 24 inches (610 mm) maximum. The high side reach shall be 48 inches (1220 mm) maximum for a reach depth of 10 inches (255 mm) maximum. Where the reach depth exceeds 10 inches (255 mm), the high side reach shall be 46 inches (1170 mm) maximum for a reach depth of 24 inches (610 mm) maximum.

309 Operable Parts

309.1 General. Operable parts required to be accessible shall comply with Section 309.

309.2 Clear Floor or Ground Space. A clear floor or ground space complying with Section 305 shall be provided.

309.3 Height. Operable parts shall be placed within one or more of the reach ranges specified in Section 308.

EXCEPTIONS:

1. Where the use of special equipment dictates otherwise.
2. Where electrical and communications systems receptacles are not normally intended for use by building occupants.

309.4 Operation. Operable parts shall be operable with one hand and shall not require tight grasping, pinching, or twisting of the wrist. The force required to activate operable parts shall be 5 pounds (22.2 N) maximum.

Chapter 4. Accessible Routes

401 General

401.1 Scope. Accessible routes required by the scoping provisions adopted by the administrative authority shall comply with the applicable provisions of this chapter.

402 Accessible Routes

402.1 General. Accessible routes shall comply with Section 402.

402.2 Components. Accessible routes shall consist of one or more of the following components: Walking surfaces with a slope not steeper than 1:20, doorways, ramps, curb ramps, elevators, and wheelchair (platform) lifts. All components of an accessible route shall comply with the applicable portions of this standard.

403 Walking Surfaces

403.1 General. Walking surfaces that are a part of an accessible route shall comply with Section 403.

403.2 Floor or Ground Surface. Floor or ground surfaces shall comply with Section 302.

403.3 Slope. The running slope of walking surfaces shall not be steeper than 1:20. The cross slope of a walking surface shall not be steeper than 1:48.

403.4 Changes in Level. Changes in level shall comply with Section 303.

403.5 Clear Width. Clear width of an accessible route shall comply with Table 403.5.

Table 403.5—Clear Width of an Accessible Route

Segment Length	Minimum Segment Width
≤ 24 inches (610 mm)	32 inches (815 mm) ¹
> 24 inches (610 mm)	36 inches (915 mm)

¹Consecutive segments of 32 inches (815 mm) wide must be separated by a route segment 48 inches (1220 mm) long minimum and 36 inches (915 mm) wide minimum.

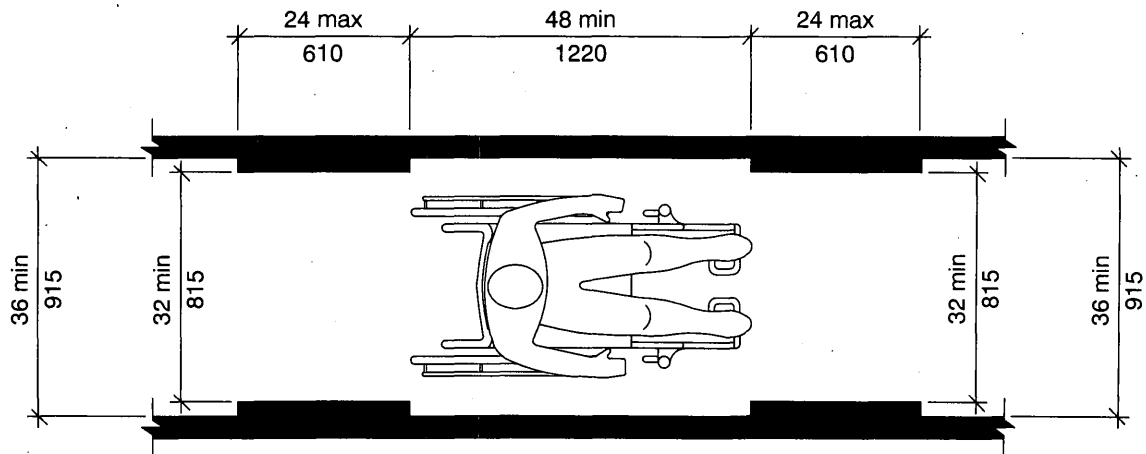

Fig. 403.5
Clear Width of an Accessible Route

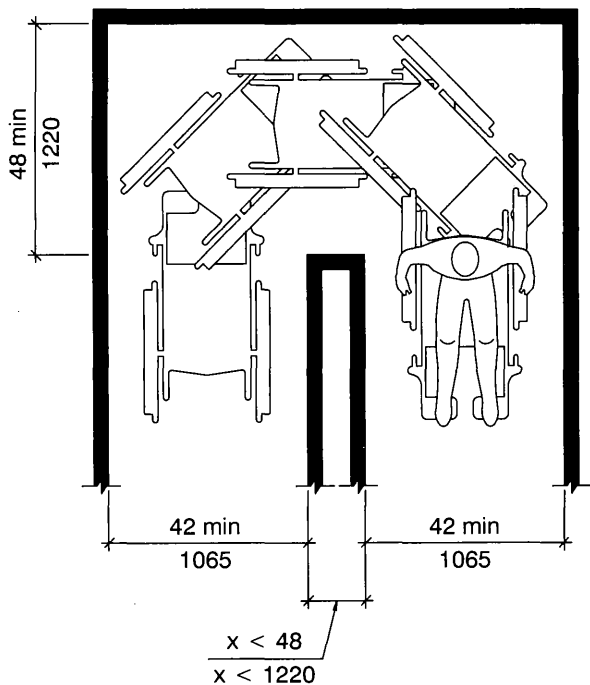

Fig. 403.5.1
Clear Width at Turn

403.5.1 Clear Width at Turn. Where an accessible route makes a 180 degree turn around an object which is less than 48 inches (1220 mm) wide, clear widths shall be 42 inches (1065 mm) minimum approaching the turn, 48 inches (1220 mm) minimum during the turn, and 42 inches (1065 mm) minimum leaving the turn.

403.5.2 Passing Space. An accessible route with a clear width less than 60 inches (1525 mm) shall provide passing spaces at intervals of 200 feet (61 m) maximum. These passing spaces shall be either a 60 inch (1525 mm) by 60 inch (1525 mm) minimum space, or an intersection of two walking surfaces which provide a T-shaped turning space complying with Section 304.

404 Doors and Doorways

404.1 General. Doors and doorways that are part of an accessible route shall comply with Section 404.

404.2 Manual Doors. Manual doors and doorways, and manual gates, including ticket gates, shall comply with the requirements of Sections 404.2.1 through 404.2.11.

404.2.1 Revolving Doors and Turnstiles. Revolving doors or turnstiles shall not be part of an accessible route.

404.2.2 Double-Leaf Doorways. At least one of the active leaves of doorways with two independently operated leaves shall comply with Sections 404.2.3 and 404.2.4.

404.2.3 Clear Width. Doorways shall have a clear opening of 32 inches (815 mm) minimum. Clear opening of doorways with swinging doors shall be measured between the face of door and stop, with the door open 90 degrees. Openings more than 24 inches (610 mm) deep shall provide a clear opening of 36 inches (915 mm) minimum. There shall be no projections into the clear opening width lower than 34 inches (865 mm) above the floor or ground. Projections into the minimum clear opening width more than 34 inches (865 mm) and up to 80 inches (2030 mm) above the floor or ground are permitted but shall not exceed 4 inches (102 mm).

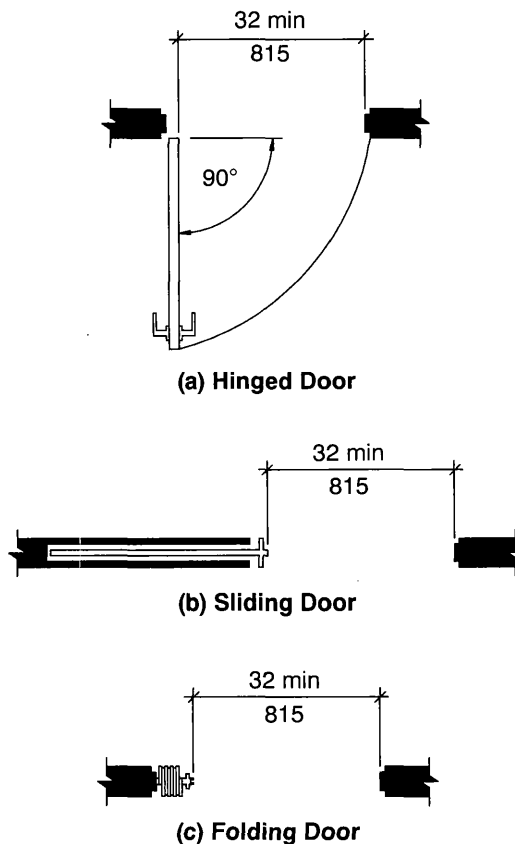

Fig. 404.2.3
Clear Width of Doorways

404.2.4 Maneuvering Clearances at Doors. Minimum maneuvering clearances at doors shall comply with Sections 404.2.4.1 through 404.2.4.7.

EXCEPTION: Doors to hospital bedrooms shall be exempt from the requirement for

space at the latch side provided the door is 44 inches (1120 mm) wide minimum.

404.2.4.1 Swinging Doors. Swinging doors shall have maneuvering clearances complying with Table 404.2.4.1.

Table 404.2.4.1—Maneuvering Clearances for Manual Swinging Doors

TYPE OF USE		MINIMUM CLEARANCES	
Approach Direction	Door Side	Perpendicular to Door ¹	Beyond Latch Parallel to Door
From front	Pull	60 inches (1525 mm)	18 inches (455 mm)
From front	Push	48 inches (1220 mm)	0 inches (0 mm) ²
From hinge	Pull	60 inches (1525 mm) 54 inches (1370 mm)	36 inches (915 mm) 42 inches (1065 mm)
From hinge	Push	42 inches (1065 mm) ³	54 inches (1370 mm)
From latch	Pull	48 inches (1220 mm) ⁴	24 inches (610 mm)
From latch	Push	42 inches (1065 mm) ⁴	24 inches (610 mm)

¹Maneuvering space shall include full width of doorway.
²Add 12 inches (305 mm) if closer and latch provided.
³Add 6 inches (150 mm) if closer and latch provided.
⁴Add 6 inches (150 mm) if closer provided.

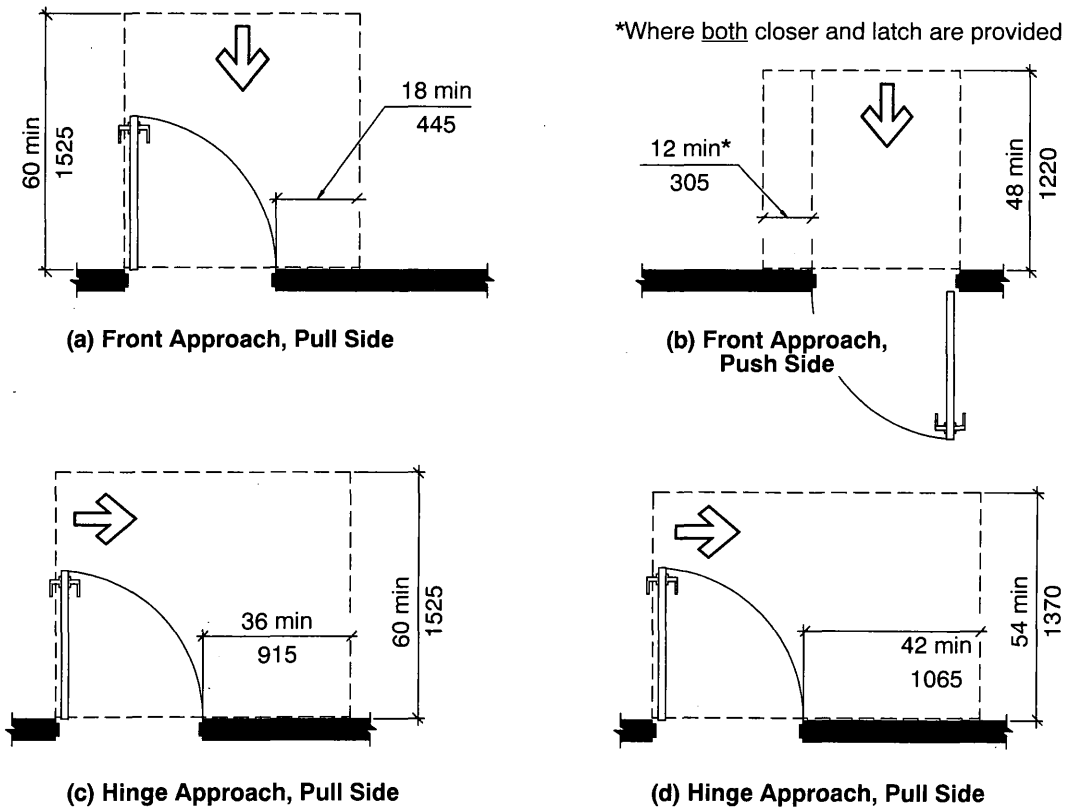

Fig. 404.2.4.1
Maneuvering Clearance at Swinging Doors

*48 min where both closer and latch are provided

*54 min where closer is provided

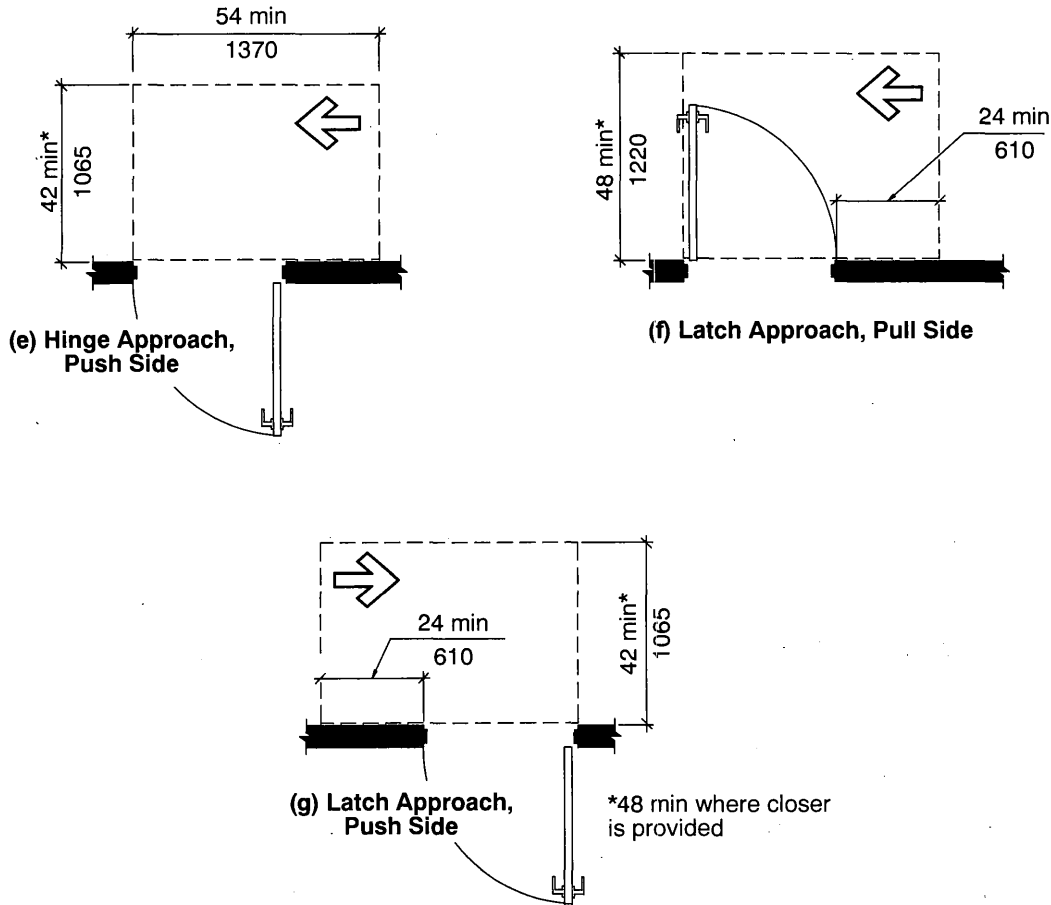

Fig. 404.2.4.1
Maneuvering Clearance at Swinging Doors (continued)

404.2.4.2 Sliding and Folding Doors. Sliding doors and folding doors shall have maneuvering clearances complying with Table 404.2.4.2.

404.2.4.3 Doorways without Doors. Doorways without doors that are less than 36 inches (915 mm) wide shall have maneuvering clearances complying with Table 404.2.4.3

Table 404.2.4.2—Maneuvering Clearances for Sliding and Folding Doors

APPROACH DIRECTION	MINIMUM CLEARANCES	
	PERPENDICULAR TO DOOR ¹	PARALLEL TO DOOR
From front	48 inches (1220 mm)	0 inches (0 mm)
From hinge side	42 inches (1065 mm)	54 inches (1370 mm) ²
From latch side	42 inches (1065 mm)	24 inches (610 mm) ²

¹Maneuvering space shall include full width of doorway.

²From the latch side toward the approach direction.

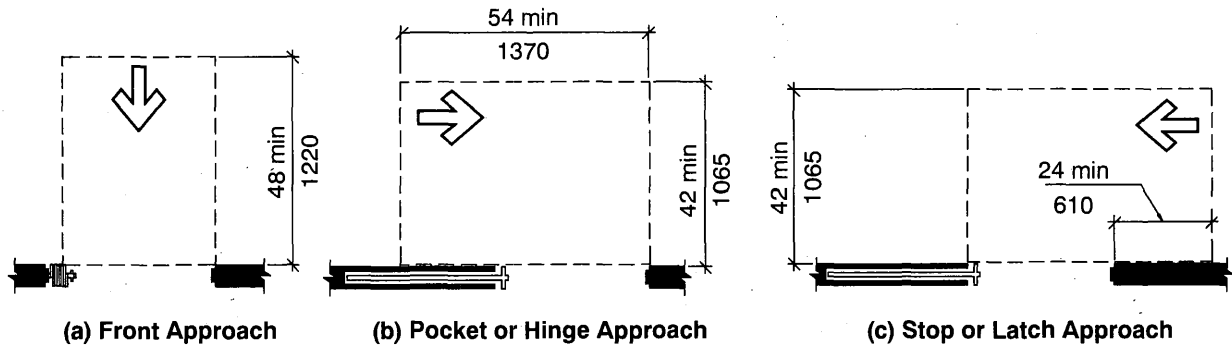

Fig. 404.2.4.2
Maneuvering Clearance at Sliding and Folding Doors

Table 404.2.4.3—Maneuvering Clearances for Doorways without Doors

Approach Direction	MINIMUM CLEARANCES
	Perpendicular to Doorway ¹
From front	48 inches (1220 mm)
From side	42 inches (1065 mm)

¹Maneuvering space shall include full width of doorway.

404.2.4.4 Recessed Doors. Where the plane of the doorway is recessed more than 8 inches (205 mm) from the plane of the wall, clearances for front approach shall be provided.

404.2.4.5 Floor or Ground Surface. Floor or ground surface within the maneuvering clearances shall have a slope not steeper than 1:48 and shall comply with Section 302.

404.2.5 Thresholds at Doorways. Thresholds, if provided, at doorways shall be 1/2 inch (13 mm) high maximum. Raised thresholds and changes in level at doorways shall comply with Sections 302 and 303.

404.2.6 Two Doors in Series. Distance between two hinged or pivoted doors in series shall be 48 inches (1220 mm) minimum plus the width of any door swinging into the space. Doors in series shall swing either in same direction or away from space between doors.

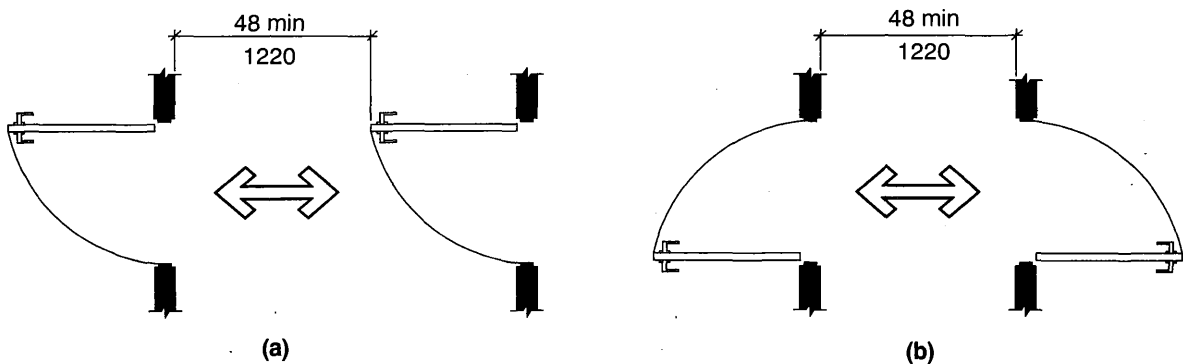

Fig. 404.2.6
Two Doors in Series

404.2.7 Door Hardware. Handles, pulls, latches, locks, and other operable parts on accessible doors shall have a shape that is easy to grasp with one hand and does not require tight grasping, pinching, or twisting of the wrist to operate. Such hardware shall be 34 inches (865 mm) minimum and 48 inches (1220 mm) maximum above the floor or ground. Where sliding doors are in the fully open position, operating hardware shall be exposed and usable from both sides.

EXCEPTION: Locks used only for security purposes and not used for normal operation are permitted in any location.

404.2.8 Closing Speed.

404.2.8.1 Door Closers. Door closers shall be adjusted so that from an open position of 90 degrees, the time required to move the door to an open position of 12 degrees shall be 5 seconds minimum.

404.2.8.2 Spring Hinges. Door spring hinges shall be adjusted so that from the open position of 70 degrees, the door shall move to the closed position in 1.5 seconds minimum, measured under ambient conditions.

404.2.9 Door-Opening Force. Fire doors shall have the minimum opening force allowable by the appropriate administrative authority. The maximum force for pushing open or pulling open doors other than fire doors shall be as follows:

1. Interior hinged door: 5.0 pounds (22.2 N)
2. Sliding or folding door: 5.0 pounds (22.2 N)

These forces do not apply to the force required to retract latch bolts or disengage other devices that hold the door in a closed position.

404.2.10 Door Surface. Door surfaces within 10 inches (255 mm) of the floor or ground measured vertically shall be a smooth surface on the push side extending the full width of the door. Parts creating horizontal or vertical joints in such surface shall be within $\frac{1}{16}$ inch (1.6 mm) of the same plane as the other. Cavities created by added kick plates shall be capped.

EXCEPTIONS:

1. Sliding doors.
2. Tempered glass doors without stiles and having a bottom rail or shoe with the top leading edge tapered at no less than

60 degrees from the horizontal shall not be required to meet the 10 inch (255 mm) bottom rail height requirement.

3. Doors which do not extend to within 10 inches (255 mm) of the floor or ground.

404.2.11 Vision Lites. Doors and sidelites adjacent to doors containing one or more glazing panels that permit viewing through the panels shall have the bottom of at least one panel 43 inches (1090 mm) maximum above the floor or ground.

404.3 Automatic Doors. Automatic doors and automatic gates shall comply with Sections 404.3.1 through 404.3.6. Full powered automatic doors shall comply with ANSI/BHMA A156.10. Low-energy and power-assisted doors shall comply with ANSI/BHMA A156.19.

404.3.1 Clear Opening Width. Doorways shall have a clear opening of 32 inches (815 mm) in power-on and power-off mode. The minimum clear width for automatic door systems shall be based on the clear opening provided by all leaves in the open position.

404.3.2 Maneuvering Clearances. Clearances at power-assisted doors shall comply with Section 404.2.4.

404.3.3 Thresholds. Thresholds and changes in level at doorways shall comply with Section 404.2.5.

404.3.4 Two Doors in Series. Doors in series shall comply with Section 404.2.6.

404.3.5 Control Switches. Control switches shall comply with Section 309.

404.3.6 Signs. Labels and warnings for automatic doors shall comply with Section 703.4.

405 Ramps

405.1 General. Walking surfaces on accessible routes with a running slope steeper than 1:20 are ramps and shall comply with Section 405.

405.2 Slope. Ramp runs shall have a running slope not steeper than 1:12.

EXCEPTION: Ramps in or on existing buildings or facilities shall be permitted to have slopes steeper than 1:12 complying with Table 405.2 where such slopes are necessitated by space limitations.

Table 405.2—Allowable Ramp Dimensions for Construction in Existing Sites, Buildings, and Facilities

Slope ¹	Maximum Rise
Steeper than 1:10 but not steeper than 1:8	3 inches (75 mm)
Steeper than 1:12 but not steeper than 1:10	6 inches (150 mm)

¹A slope steeper than 1:8 shall not be permitted.

405.3 Cross Slope. Cross slope of ramp runs shall not be steeper than 1:48.

405.4 Floor or Ground Surfaces. Floor or ground surfaces of ramp runs shall comply with Section 302.

405.5 Clear Width. The clear width of a ramp run shall be 36 inches (915 mm) minimum.

405.6 Rise. The rise for any ramp run shall be 30 inches (760 mm) maximum.

405.7 Landings. Ramps shall have landings at bottom and top of each run. Landings shall comply with Sections 405.7.1 through 405.7.5.

405.7.1 Slope. Landings shall have a slope not steeper than 1:48 and shall comply with Section 302.

405.7.2 Width. Clear width of landings shall be at least as wide as the widest ramp run leading to the landing.

405.7.3 Length. Landing length shall be 60 inches (1525 mm) minimum clear.

405.7.4 Change in Direction. Ramps that change direction at landings shall have a 60 inch (1525 mm) minimum by 60 inch (1525 mm) minimum landing.

405.7.5 Doorways. Where doorways are adjacent to a ramp landing, maneuvering clearances required by Sections 404.2.4 and 404.3.2 shall be permitted to overlap the landing area.

405.8 Handrails. Ramps with a rise greater than 6 inches (150 mm) shall have handrails complying with Section 505. Handrails shall not reduce the required clearances of a ramp run or landing.

405.9 Edge Protection. Edge protection complying with Section 405.9.1 or 405.9.2 shall be provided on each side of ramp runs and at each side of ramp landings.

EXCEPTIONS:

1. Ramps not required to have handrails where sides complying with Section 406.4 are provided.
2. Sides of ramp landings serving an adjoining ramp run or stairway.
3. Sides of ramp landings having a vertical drop-off of 1/2 inch (13 mm) maximum within 10 inches (255 mm) horizontally of the minimum landing area.

405.9.1 Extended Floor or Ground Surface.

The floor or ground surface of the ramp run or landing shall extend 12 inches (305 mm) minimum beyond the inside face of a railing complying with Section 505.

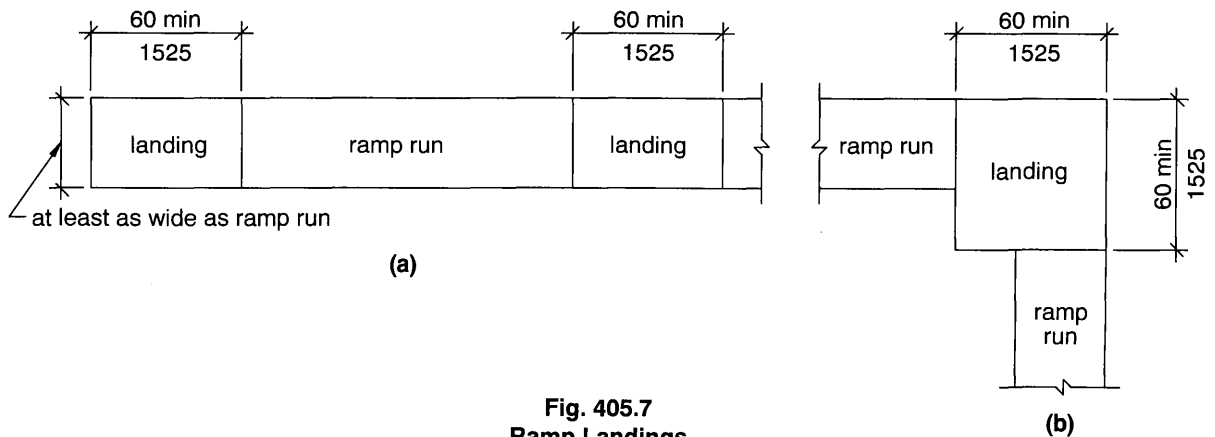

**Fig. 405.7
Ramp Landings**

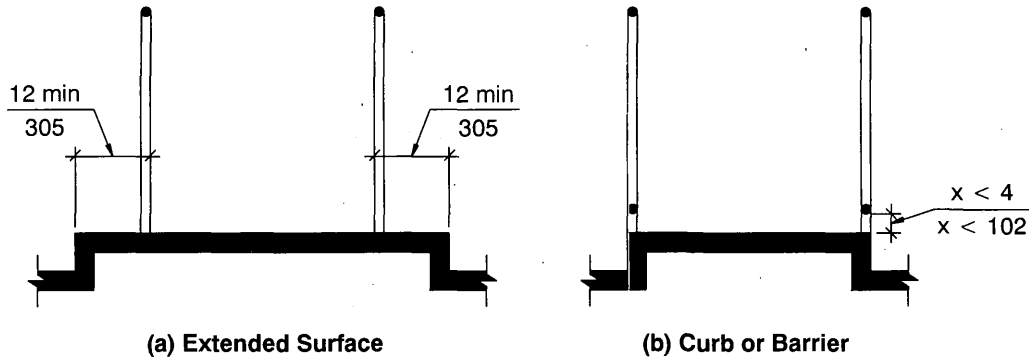

Fig. 405.9
Ramp Edge Protection

405.9.2 Curb or Barrier. A curb or barrier shall be provided that prevents the passage of a 4-inch (102 mm) diameter sphere below a height of 4 inches (102 mm).

405.10 Outdoor Conditions. Outdoor ramps and approaches to ramps shall be designed so that water will not accumulate on walking surfaces.

406 Curb Ramps

406.1 General. Curb ramps on accessible routes shall comply with Section 406.

406.2 Slope. Slopes of curb ramps shall comply with Section 405.2.

406.3 Counter Slope. Counter slopes of adjoining gutters and road surfaces immediately adjacent to the curb ramp or accessible route shall not be steeper than 1:20. Transitions from ramps to walks, gutters or streets shall be at the same level.

406.4 Sides of Curb Ramps. Where pedestrians must walk across a curb ramp, the ramp shall have flared sides. Slope of flares shall not be steeper than 1:10. Where the width of the walking surface at the top of the ramp and parallel to the run of the ramp is less than 48 inches (1220 mm) wide, the flared

sides shall have a slope not steeper than 1:12. Curb ramps with returned curbs shall be permitted where pedestrians would not normally walk across the ramp.

406.5 Width. Curb ramps shall be 36 inches (915 mm) wide minimum, exclusive of flared sides.

406.6 Floor or Ground Surface. Floor or ground surfaces of curb ramps shall comply with Section 302.

406.7 Location. Curb ramps and their side flares shall not protrude into vehicular traffic lanes, parking spaces, or into parking space access aisles.

406.8 Obstructions. Curb ramps shall be located or protected to prevent their obstruction by parked vehicles.

406.9 Handrails. Handrails are not required on curb ramps.

406.10 Location at Marked Crossings. Curb ramps at marked crossings shall be wholly contained within the markings, excluding any flared sides.

406.11 Diagonal Curb Ramps. Diagonal or corner-type curb ramps with returned curbs or other

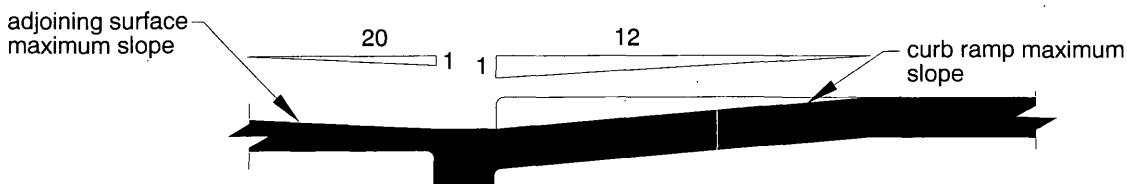

Fig. 406.3
Counter Slope of Surfaces Adjacent to Curb Ramps

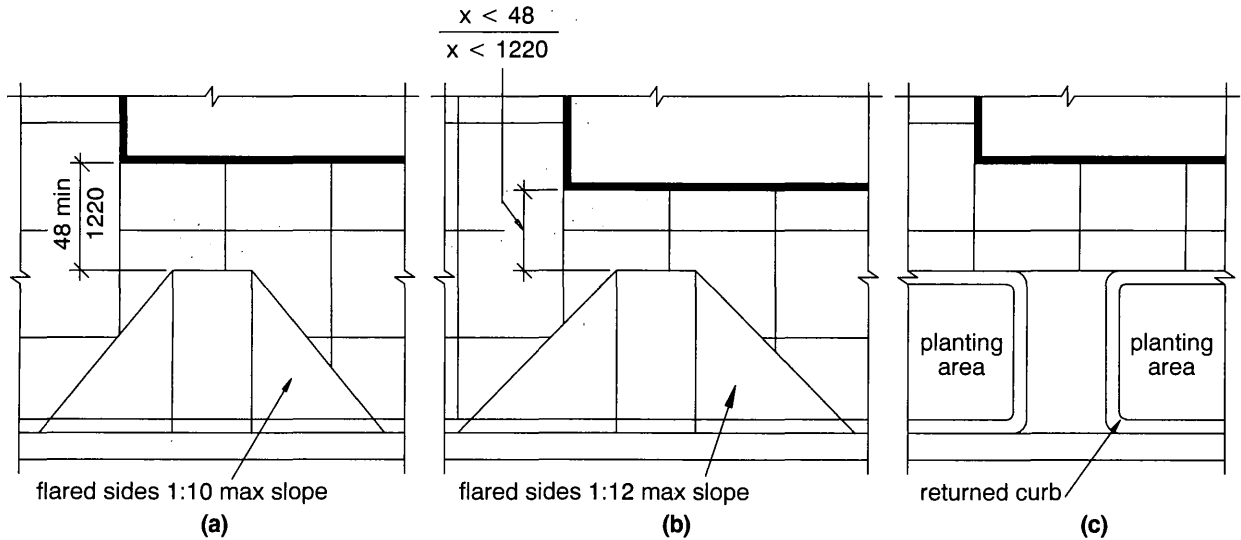

Fig. 406.4
Sides of Curb Ramps

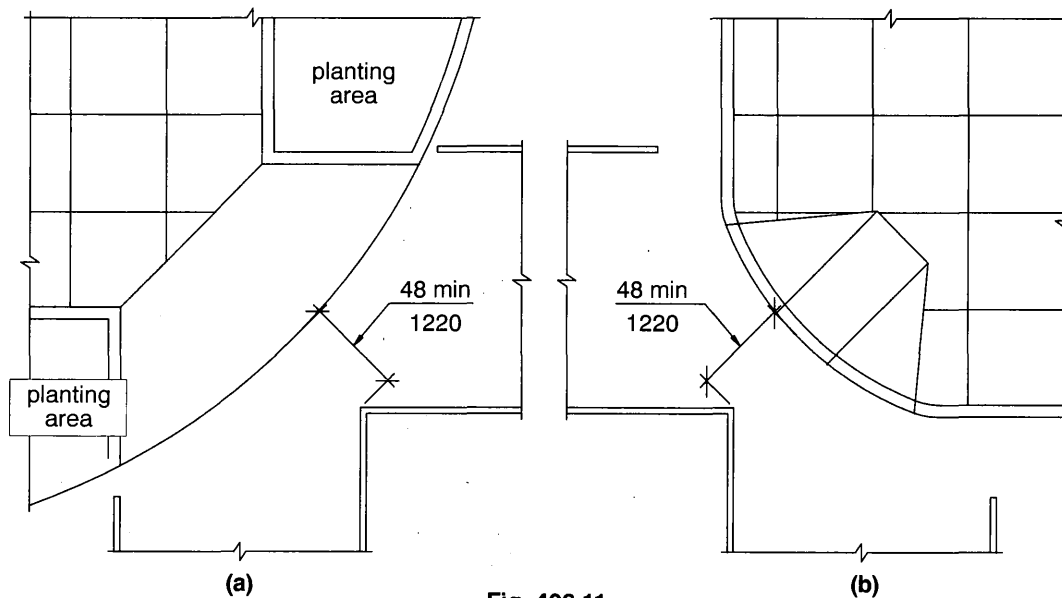

Fig. 406.11
Diagonal Curb Ramps

well-defined edges shall have the edges parallel to the direction of pedestrian flow. Bottoms of diagonal curb ramps shall have 48 inches (1220 mm) minimum clear space, measured parallel to the running slope. Diagonal curb ramps provided at marked crossings shall provide the minimum clear space within the markings. Diagonal curb ramps with flared sides shall have a segment of straight curb 24 inches (610 mm) long minimum on each side of the curb ramp and within the marked crossing.

406.12 Islands. Raised islands in crossings shall be cut through level with the street or have curb

ramps at both sides, and a level area 48 inches (1220 mm) long minimum by 36 inches (915 mm) wide minimum, in the part of the island intersected by the crossing.

407 Elevators

407.1 General. Elevators required to be accessible shall comply with Section 407.2. Destination-oriented elevators required to be accessible shall comply with Section 407.3. Limited use/limited application elevators required to be accessible shall

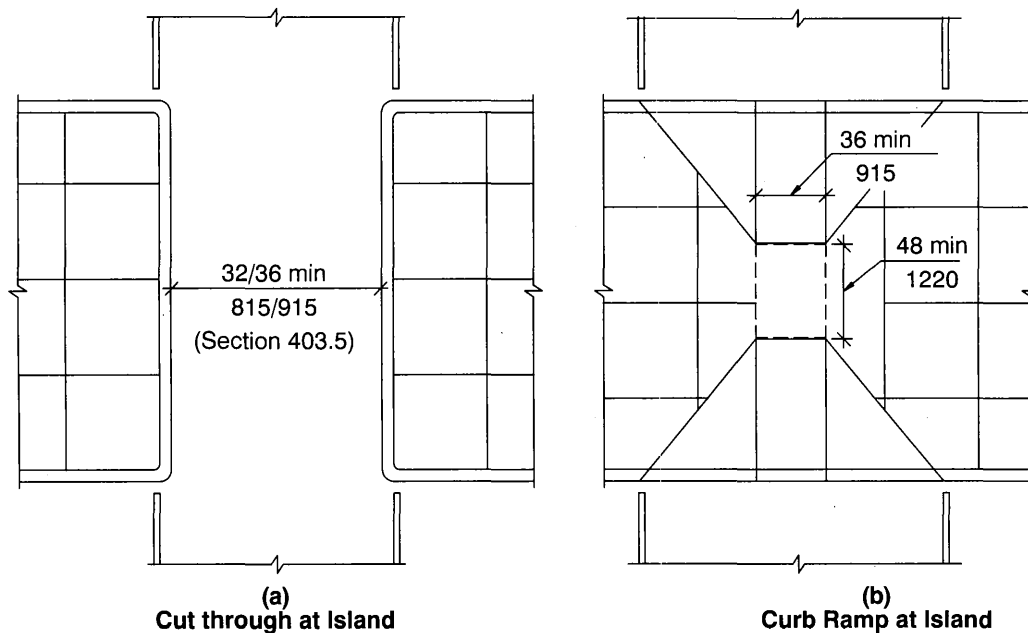

Fig. 406.12
Islands

comply with Section 407.4. Altered elements of existing elevators shall comply with Section 407.5.

407.2 Elevators. Elevators shall comply with Sections 407.2.1 through 407.2.13 and ASME/ANSI A17.1. They shall be passenger elevators.

407.2.1 Automatic Operation. Elevator operation shall be automatic. Each car shall be equipped with a self-leveling feature that will automatically bring and maintain the car at floor landings within a tolerance of 1/2 inch (13 mm) under rated loading to zero loading conditions.

407.2.2 Call Buttons. Call buttons in elevator lobbies and halls shall be 35 inches (890 mm) minimum and 48 inches (1220 mm) maximum above the floor or ground, measured to the centerline of the buttons. A clear floor or ground space complying with Section 305 shall be provided. Such call buttons shall have visual signals to indicate when each call is registered and when each call is answered. Call buttons shall be 3/4 inch (19 mm) minimum in their smallest dimension. The button that designates the up direction shall be above the button that

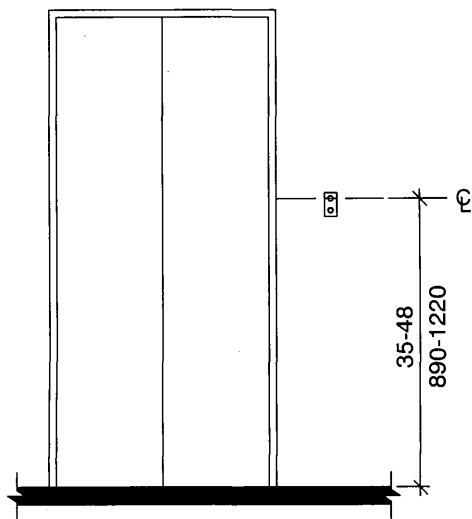

Fig. 407.2.2
Elevator Call Buttons

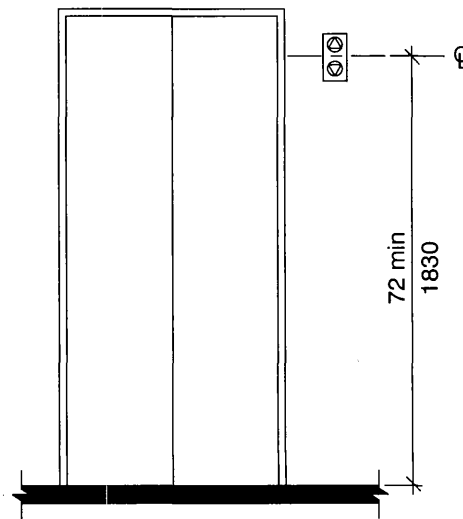

Fig. 407.2.3.2.1
Height of Elevator Visible Signals

designates the down direction. Buttons shall be raised or flush. Objects beneath hall call buttons shall protrude 1 inch (25 mm) maximum.

407.2.3 Hall Signals. A visible and audible signal shall be provided at each hoistway entrance to indicate which car is answering a call and the direction of travel, except that signals in cars, visible from the floor area adjacent to the hall call buttons, and complying with the requirements of this subsection, shall be permitted.

407.2.3.1 Audible Signals. Audible signals shall sound once for the up direction and twice for the down direction, or shall have verbal annunciators that state the word "up" or "down." Audible signals shall have a frequency of 1500 Hz maximum. The audible signal or verbal annunciator shall be 10 dBA minimum above ambient, but shall not exceed 80 dBA maximum, measured at the hall call button.

407.2.3.2 Visible Signals. Visible signals shall comply with Sections 407.2.3.2.1 through 407.2.3.2.3.

407.2.3.2.1 Height. Hall signal fixtures shall be 72 inches (1830 mm) minimum above the floor or ground, measured to the centerline of the fixture.

407.2.3.2.2 Size. The visible signal elements shall be 2 1/2 inches (64 mm) minimum in their smallest dimension.

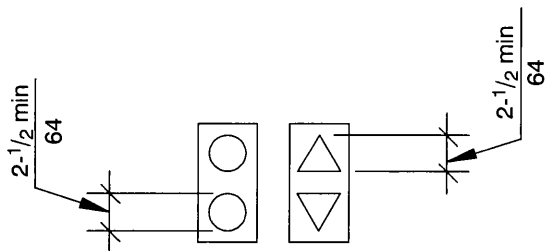

Fig. 407.2.3.2.2
Size of Elevator Visible Signals

407.2.3.2.3 Visibility. Signals shall be visible from the floor area adjacent to the hall call button.

407.2.4 Tactile Characters on Hoistway Entrances. Tactile character and Braille floor designations shall be provided on both jambs of elevator hoistway entrances and shall be 60 inches (1525 mm) above the floor or ground,

measured from the baseline of the characters. A tactile star shall also be provided on both jambs at the main entry level. Such characters shall be 2 inches (51 mm) high and shall comply with Section 703.2.

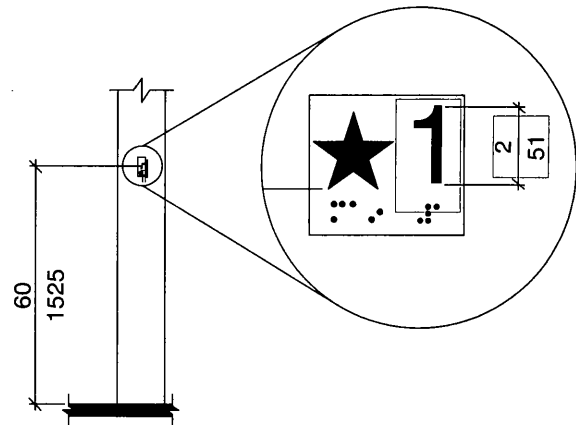

Fig. 407.2.4
Tactile Characters on Elevator Hoistway Entrances

407.2.5 Doors. Elevator doors shall be the horizontal type. Elevator hoistway and car doors shall open and close automatically. Elevator doors shall be provided with a reopening device that shall stop and reopen a car door and hoistway door automatically if the door becomes obstructed by an object or person. The device shall be activated by sensing an obstruction passing through the door opening at 5 inches (125 mm) and at 29 inches (735 mm) above the floor or ground. The device shall not require physical contact to be activated, although contact may occur before the door reverses. Door reopening devices shall remain effective for 20 seconds minimum.

407.2.6 Door and Signal Timing for Hall Calls. The minimum acceptable time from notification that a car is answering a call until the door starts to close shall be calculated by the following equation, but shall not be less than 5 seconds:

$$T = D/1.5 \text{ ft/s (D/455 mm/s)}$$

where T = total time in seconds and D = distance in feet (millimeters) from the point in the lobby or corridor 60 inches (1525 mm) directly in front of the farthest call button controlling that car to the centerline of its hoistway door. For cars with in-car signals, T begins when the signal is visible from the point 60 inches (1525 mm) directly in front of the farthest hall call button and the audible signal is sounded.

407.2.7 Door Delay for Car Calls. Elevator doors shall remain fully open in response to a car call for 3 seconds minimum.

407.2.8 Inside Dimensions of Elevator Cars. The clear width of elevator doors and the inside dimensions of elevator cars shall comply with Table 407.2.8.

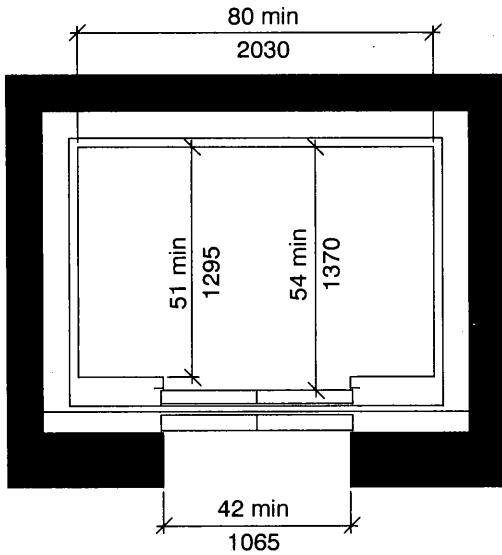

(a) Centered Door Location

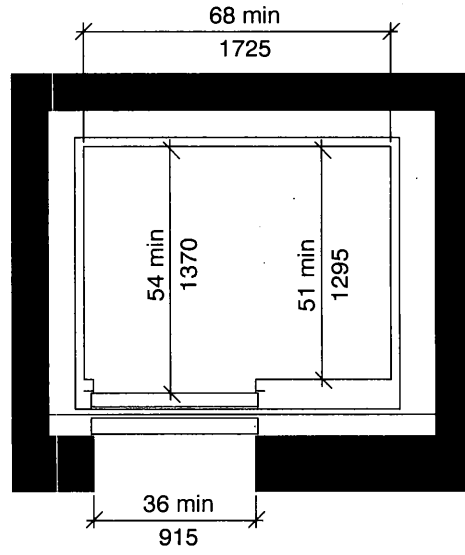

(b) Off-Centered Door Location

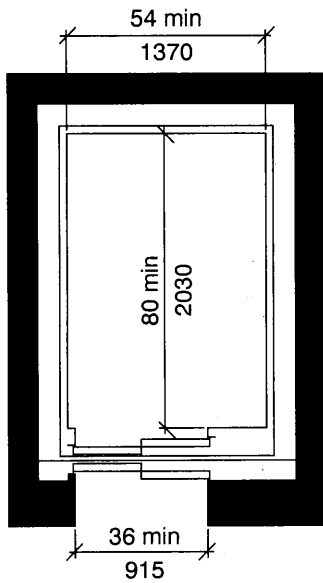

(c) Any Door Location

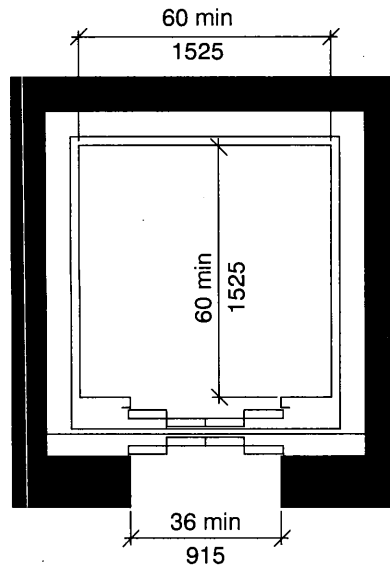

(d) Any Door Location

Fig. 407.2.8
Inside Dimensions of Elevator Cars

Table 407.2.8—Minimum Dimensions of Elevator Cars¹

Door Location	Door Clear Width	Inside Car, Side to Side	Inside Car, Back Wall to Front Return	Inside Car, Back Wall to Inside Face of Door
Centered	42 inches (1065 mm)	80 inches (2030 mm)	51 inches (1295 mm)	54 inches (1370 mm)
Side (Off Center)	36 inches (915 mm) ²	68 inches (1725 mm)	51 inches (1295 mm)	54 inches (1370 mm)
Any	36 inches (915 mm) ²	54 inches (1370 mm)	80 inches (2030 mm)	80 inches (2030 mm)
Any	36 inches (915 mm) ²	60 inches (1525 mm)	60 inches (1525 mm)	60 inches (1525 mm)

¹Other car configurations that provide a 36 inch (915 mm) clear door width and a turning space complying with Section 304 with the door closed are permitted.

²A tolerance of minus 5/8 inch (16 mm) is permitted.

407.2.9 Floor Surfaces. Floor surfaces in elevator cars shall comply with Section 302. The horizontal clearance between the edge of the car platform sill and the edge of the landing sill shall be 1 1/4 inches (32 mm) maximum.

407.2.10 Illumination Levels. The level of illumination at the car controls, platform, and car threshold and landing sill shall be 5 footcandles (54 lux) minimum.

407.2.11 Car Controls. Elevator controls shall comply with Sections 407.2.11.1 through 407.2.11.4.

407.2.11.1 Buttons. Buttons shall be 3/4 inch (19 mm) minimum in their smallest dimension. Buttons shall be raised or flush. Except where provided in a standard tele-

phone keypad arrangement, buttons shall be arranged with numbers in ascending order. Where two or more columns of buttons are provided they shall read from left to right.





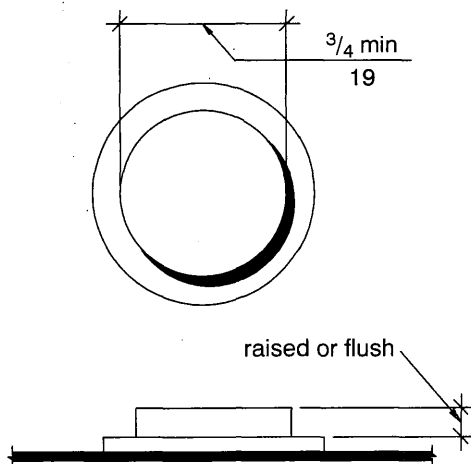





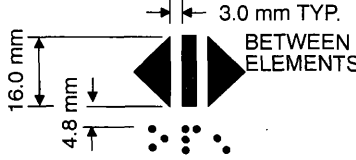
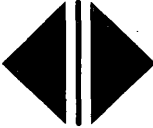

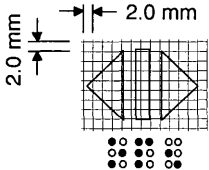

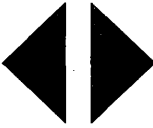
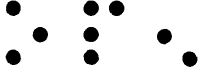
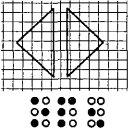

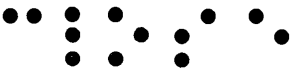
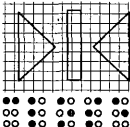

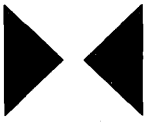
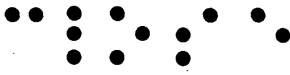
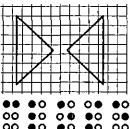

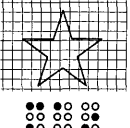

407.2.11.2 Button Designations. Except where provided in a standard telephone keypad arrangement, control buttons shall be identified by tactile characters complying with Section 703.2. Tactile characters and Braille shall be placed immediately to the left of the button to which they apply. The control button for the main entry floor, and control buttons other than remaining buttons with floor designations, shall be identified with tactile symbols complying with Table 407.2.11.2. Buttons with floor designations shall be provided with visible indicators to show that a call has been registered. The visible indication shall extinguish when the car arrives at the designated floor.

Telephone-style keypads shall be in a standard telephone keypad arrangement, and shall be identified by characters complying with Section 703.4. The number five key shall have a single raised dot. The dot shall be 0.118 inch (3 mm) to 0.120 inch (3.05 mm) base diameter and in other aspects comply with Table 703.5. Characters shall be centered on the corresponding keypad button. A display shall be provided in the car with visible indicators to show registered car destinations. The visible indication shall extinguish when the car arrives at the designated floor. A standard five-pointed star shall be used to indicate the main entry floor.

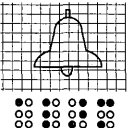

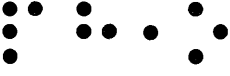
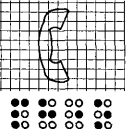
**Fig. 407.2.11.1
Elevator Car Control Buttons**

Table 407.2.11.2—Control Button Identification

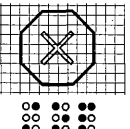
Control Button	Tactile Symbol	Braille Message	Proportions Open circles indicate unused dots within each Braille Cell
 <p>DOOR OPEN</p>		 <p>OP"EN"</p>	
 <p>REAR/SIDE DOOR OPEN</p>		 <p>REAR/SIDE OP"EN"</p>	
 <p>DOOR CLOSE</p>		 <p>CLOSE</p>	
 <p>REAR/SIDE DOOR CLOSE</p>		 <p>REAR/SIDE CLOSE</p>	
 <p>MAIN</p>		 <p>MA"IN"</p>	
 <p>ALARM</p>		 <p>AL"AR"M</p>	
 <p>PHONE</p>		 <p>PH"ONE"</p>	
 <p>EMERGENCY STOP (WHEN PROVIDED) X on face of octagon is not required to be tactile</p>		 <p>"ST"OP</p>	

407.2.11.3 Height. Buttons with floor designations shall be 48 inches (1220 mm) maximum above the floor or ground. Emergency controls, including the emergency alarm, shall be grouped at the bottom of the panel. Emergency control buttons shall have their centerlines 35 inches (890 mm) minimum above the floor or ground.

EXCEPTION: Where the elevator serves more than 16 openings and parallel approach is provided, buttons with floor designations shall be 54 inches (1370 mm) maximum above the floor or ground.

407.2.11.4 Clear Floor or Ground Space. A clear floor or ground space complying with Section 305 shall be provided at controls.

407.2.12 Car Position Indicators. In elevator cars, both audible and visible indicators shall be provided to identify the floor location of the car.

407.2.12.1 Visible Indicators. Indicator shall be above the car control panel or above the door. Numerals shall be $\frac{1}{2}$ inch (13 mm) high minimum. As the car passes or stops at a floor served by the elevator, the corresponding character shall illuminate.

407.2.12.2 Audible Indicators. The audible signal shall be 10 dBA minimum above ambient, but shall not exceed 80 dBA maximum, measured at the annunciator. The signal shall be an automatic verbal announcement which announces the floor at which the car has stopped.

EXCEPTION: For elevators that have a rated speed of 200 fpm (1 m/s) or less, an audible signal with a frequency of 1500 Hz maximum which sounds as the car passes or stops at a floor served by the elevator shall be permitted.

407.2.13 Emergency Communications. Emergency two-way communication systems between the elevator car and a point outside the hoistway shall comply with ASME/ANSI A17.1. The highest operable part of a two-way communication system shall comply with Section 308.3. If the device is in a closed compartment, the compartment door hardware shall comply with Section 309. Tactile symbols and characters complying with Section 703.2 shall be provided adjacent to the device. If the system uses a handset, the cord from the panel to the handset shall be 29 inches (735 mm) long minimum. The car emergency signaling device shall not

be limited to voice communication. If instructions for use are provided, essential information shall be presented in both tactile and visual form complying with Section 703.

407.3 New Destination-Oriented Elevators. Destination-oriented elevators shall also comply with Sections 407.3.1 through 407.3.6 and 407.2.13. Such elevators shall also comply with Sections 407.3.1 through 407.3.6 and ASME/ANSI A17.1. They shall be passenger elevators.

407.3.1 Call Buttons. Call buttons shall be 35 inches (890 mm) minimum and 48 inches (1220 mm) maximum above the floor or ground, measured to the centerline of the buttons. A clear floor or ground space complying with Section 305 shall be provided. Call buttons shall be $\frac{3}{4}$ inch (19 mm) minimum in their smallest dimension. Buttons shall be raised or flush. Objects beneath hall call buttons shall protrude 1 inch (25 mm) maximum into the clear floor or ground space. Destination-oriented elevator systems shall have a keypad or other means for the entry of destination information. Keypads, if provided, shall be in a standard telephone keypad arrangement, and shall be identified by characters complying with Section 703.4. The number five key shall have a single raised dot. The dot shall be 0.118 inch (3 mm) to 0.120 inch (3.05 mm) base diameter, and in other aspects comply with Table 703.5. Destination-oriented elevator systems shall be provided with visual and audible signals which indicate which elevator car to enter. Characters shall be centered on the corresponding keypad button. A display shall be provided in the car with visible indicators to show registered car destinations. The visible indication shall extinguish when the car arrives at the designated floor. A standard five-pointed star shall be used to indicate the main entry floor.

407.3.2 Hall Signals. A visible and audible signal shall be provided to indicate a car destination corresponding with Section 407.3.1. The audible tone and verbal announcement shall be the same as those given at the call button or call button keypad, if provided. Each elevator in a bank shall have audible and visual means for differentiation.

407.3.2.1 Visible Signals. Visible signals shall comply with Sections 407.3.2.1.1 through 407.3.2.1.3.

407.3.2.1.1 Height. Hall signal fixtures shall be 72 inches (1830 mm) minimum above the floor or ground, measured to the centerline of the fixture.

407.3.2.1.2 Size. The visible signal elements shall be $2\frac{1}{2}$ inches (64 mm) minimum in their smallest dimension.

407.3.2.1.3 Visibility. Signals shall be visible from the floor area adjacent to the hoistway entrance.

407.3.3 Car Controls. Emergency controls, including the emergency alarm, shall have their centerlines 35 inches (890 mm) minimum and 48 inches (1220 mm) maximum above the floor or ground. Buttons shall be $\frac{3}{4}$ inch (19 mm) minimum in their smallest dimension. Buttons shall be raised or flush. Controls shall accommodate a forward reach or side reach complying with Section 308.

407.3.4 Car Position Indicators. In elevator cars, audible and visible car location indicators shall be provided.

407.3.4.1 Visible Indicators. Indicators shall be above the car control panel or above the door. Numerals shall be $\frac{1}{2}$ inch (13 mm) high minimum. The visible indicators shall extinguish when the car arrives at the designated floor.

407.3.4.2 Audible Indicators. An automatic verbal announcement which announces the floor at which the car has stopped shall be provided. The announcement shall be 10 dBA minimum above ambient and 80 dBA maximum, measured at the annunciator.

407.3.5 Elevator Car Identification. In addition to the tactile signs required by Section 407.2.4, a tactile elevator car identification shall be placed immediately below the hoistway entrance floor designation. The characters shall

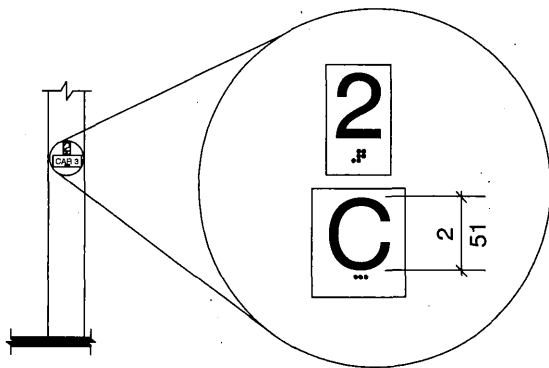

Fig. 407.3.5
Destination-Oriented Elevator Car Identification

be 2 inches (51 mm) high and shall comply with Section 703.2.

407.3.6 Door and Signal Timing for Hall Calls. The minimum acceptable time from notification of the car assigned at the keypad until the door starts to close shall be calculated by the following equation, but shall not be less than 5 seconds:

$$T = D/1.5 \text{ ft/s (D/455 mm/s)}$$

where T = total time in seconds and D = distance in feet (millimeters) from the keypad to the centerline of the assigned hoistway door.

407.4 Limited-Use/Limited-Application Elevators. Limited-use/limited-application elevators shall comply with Sections 407.4.1 through 407.4.10 and ASME/ANSI A17.1, Part XXV.

407.4.1 Automatic Operation. Elevator operation shall be automatic. Each car shall automatically stop at a floor landing within a tolerance of $\frac{1}{2}$ inch (13 mm) under rated loading to zero loading conditions.

407.4.2 Call Buttons. Call buttons in elevator lobbies and halls shall be 35 inches (890 mm) minimum and 48 inches (1220 mm) maximum above the floor or ground, measured to the centerline of the buttons. Such call buttons shall have visual signals to indicate when each call is registered and when each call is answered. Call buttons shall be $\frac{3}{4}$ inch (19 mm) minimum in their smallest dimension, and shall be raised or flush. The button that designates the up direction shall be above the button that designates the down direction. Objects beneath hall call buttons shall protrude 1 inch (25 mm) maximum.

407.4.3 Hall Signals. A visible and audible signal complying with Section 407.2.3 shall be provided in the car or at the hoistway entrance to indicate the direction of travel.

407.4.4 Tactile Characters on Hoistway Entrances. Tactile character and Braille floor designations shall be provided on both jambs of elevator hoistway entrances and shall be 60 inches (1525 mm) above the floor or ground, measured from the baseline of the characters. A tactile star shall also be provided on both jambs at the main entry level. Such characters shall be 2 inches (51 mm) high and shall comply with Section 703.2.

407.4.5 Doors. Elevator hoistway doors shall be either swinging or horizontally sliding type. Elevator doors shall open and close automati-

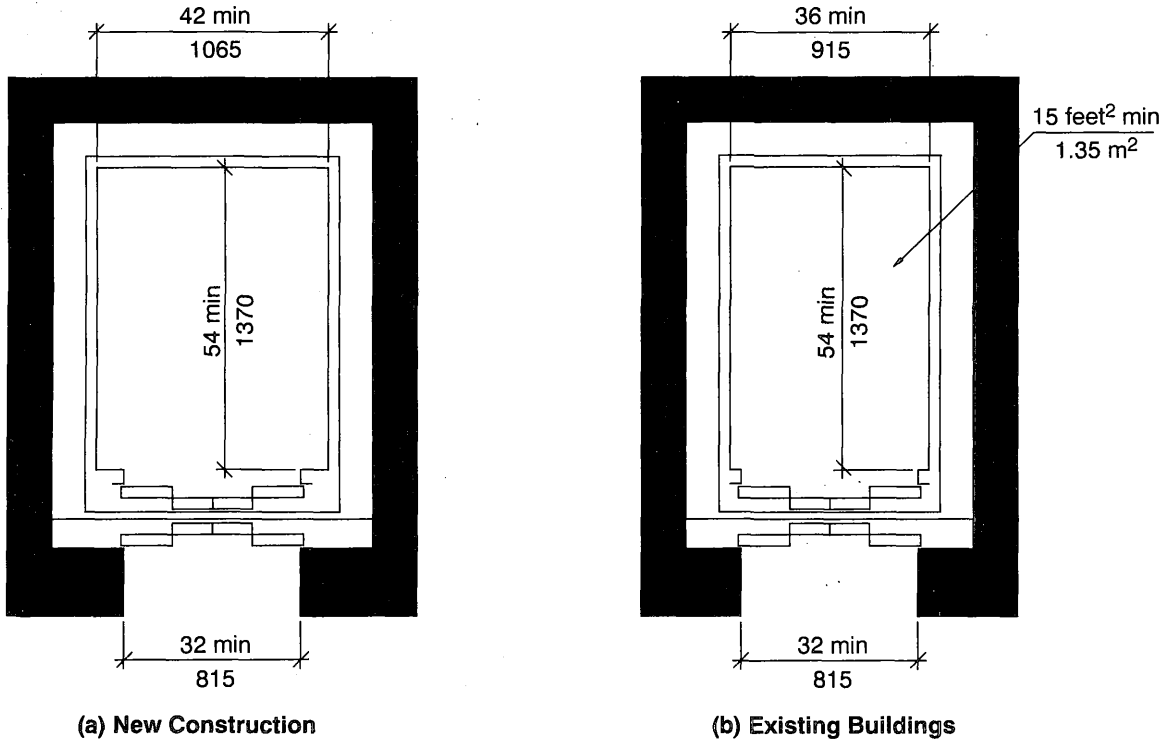

Fig. 407.4.6
Inside Dimensions of Limited Use/Limited Application (LULA) Elevator Cars

cally. Horizontally sliding type hoistway and car doors shall comply with Section 407.2.5. Swinging hoistway and car doors shall comply with Section 404. Swinging doors shall be low energy power-operated and shall comply with ANSI/BHMA A156.19. Power operated swinging doors shall remain open for 20 seconds minimum when activated.

407.4.6 Inside Dimensions of Elevator Cars. Elevator cars shall provide a clear width of 42 inches (1065 mm) minimum and a clear depth of 54 inches (1370 mm) minimum. Car doors shall be positioned at the narrow end(s) of the car and shall provide a clear width of 32 inches (815 mm) minimum.

EXCEPTION: For installations in existing buildings, elevator cars shall provide a clear width of 36 inches (915 mm) minimum, a clear depth of 54 inches (1370 mm) minimum, and a net clear platform area of 15 square feet (1.35 m²) minimum.

407.4.7 Floor or Ground Surfaces. Floor or ground surfaces in elevator cars shall comply with Section 302. The horizontal distance between the car platform sill and the edge of any hoistway landing shall be 1¹/₄ inches (32 mm) maximum.

407.4.8 Illumination Levels. The level of illumination at the car controls, platform, and car threshold and landing sill shall be 5 footcandles (54 lux) minimum.

407.4.9 Car Controls. Elevator car controls shall comply with Sections 407.4.9.1 through 407.4.9.4.

407.4.9.1 Buttons. Control buttons shall be 3/4 inch (19 mm) minimum in their smallest dimension. Control buttons shall be raised or flush. Control buttons shall be arranged with numbers in ascending order.

407.4.9.2 Identification. Control buttons shall be identified by tactile characters complying with Section 703.2. Tactile characters shall be placed immediately to the left of the button to which they apply. The control button for the main entry floor shall be identified with a tactile symbol complying with Table 407.2.11.2. Buttons with floor designations shall be provided with visible indicators to show that a call has been registered. The visible indication shall extinguish when the car arrives at the designated floor.

407.4.9.3 Height. Buttons with floor designations shall be 48 inches (1220 mm) maxi-

imum above the floor. Emergency controls, including the emergency alarm, shall be grouped at the bottom of the panel. Emergency control buttons shall have their centerlines 35 inches (890 mm) minimum above the floor.

407.4.9.4 Location. Controls shall be on a side wall and a clear floor or ground space complying with Section 309.2 shall be provided.

407.4.10 Emergency Communications.

Emergency two-way communication systems between the elevator car and a point outside the hoistway shall comply with ASME/ANSI A17.1. The highest operable part of a two-way communication system shall comply with Section 308.3. If the device is in a closed compartment, the compartment door hardware shall comply with Section 309. Tactile symbols and characters complying with Section 703.2 shall be provided adjacent to the device. If the system uses a handset, the cord from the panel to the handset shall be 29 inches (735 mm) long minimum. The car emergency signaling device shall not be limited to voice communication. If instructions for use are provided, essential information shall be presented in both tactile and visual form complying with Section 703.

407.5 Existing Elevators. Accessible elements of existing elevators shall comply with Sections 407.5, 407.2.4, 407.2.6, 407.2.7, 407.2.9, 407.2.10, and 407.2.13. They shall be passenger elevators as classified by ASME/ANSI A17.1.

EXCEPTION: Destination-oriented elevators which comply with Section 407.3.

407.5.1 Automatic Operation. Elevator operation shall be automatic. Each car shall be equipped with a self-leveling feature that will automatically bring and maintain the car at floor landings within a tolerance of $\frac{1}{2}$ inch (13 mm) under rated loading to zero loading conditions.

407.5.2 Call Buttons. Call buttons in elevator lobbies shall be 35 inches (890 mm) minimum and 48 inches (1220 mm) maximum above the floor or ground, measured to the centerline of the button, where the appropriate floor or ground area complying with Section 305 is provided. The button that designates the up direction shall be above the button that designates the down direction. Keypad controls complying with Section 407.2.2 shall be permitted.

407.5.3 Hall Signals. A visible and audible signal shall be provided at each hoistway entrance to indicate which car is answering a call, except

that in-car signals complying with Section 407.2.3 shall be permitted. Audible signals shall sound once for the up direction and twice for the down direction, or shall have verbal annunciators that state the word "up" or "down." If new hall signals are provided, they shall comply with Section 407.2.3.

407.5.4 Doors. Doors shall comply with Section 407.5.4.1 or 407.5.4.2.

407.5.4.1 Power Operated Doors. Power operated horizontally sliding car and hoistway doors opened and closed by automatic means shall comply with Section 407.2.5.

407.5.4.2 Manually Operated Doors. Existing manually operated hoistway swinging doors shall comply with Sections 404.2.3 and 404.2.9. A power operated car door that opens and maintains a 32 inch (815 mm) minimum clear width shall be provided. Closing of the car door shall not be initiated until the hoistway door is closed. Car gates are prohibited.

407.5.5 Inside Dimension of Elevator Cars. The inside dimension of elevator cars shall comply with Section 407.2.8.

EXCEPTION: Existing car configurations that provide a clear floor area of 16 square feet (1.45 m²) minimum, and provide 48 inches (1220 mm) minimum inside clear depth and a 36 inch (915 mm) minimum clear width.

407.5.6 Car Controls. Elevator controls shall comply with Sections 407.5.6.1 through 407.5.6.4.

407.5.6.1 Buttons. Car control buttons shall be $\frac{3}{4}$ inch (19 mm) minimum in their smallest dimension. Control buttons shall be raised, flush or recessed. Where the car operating panel is changed, control buttons shall comply with Section 407.2.11.1.

407.5.6.2 Designations and Indicators for Control Buttons. All control buttons shall comply with Section 407.2.11.2.

EXCEPTION: Where existing car operating panel construction precludes locating tactile markings to the left of the controls, markings shall be placed as near to the control as possible.

407.5.6.3 Height. All buttons with floor designations shall be 54 inches (1370 mm) maximum above the floor for parallel approach and 48 inches (1220 mm) maximum above the floor for forward approach.

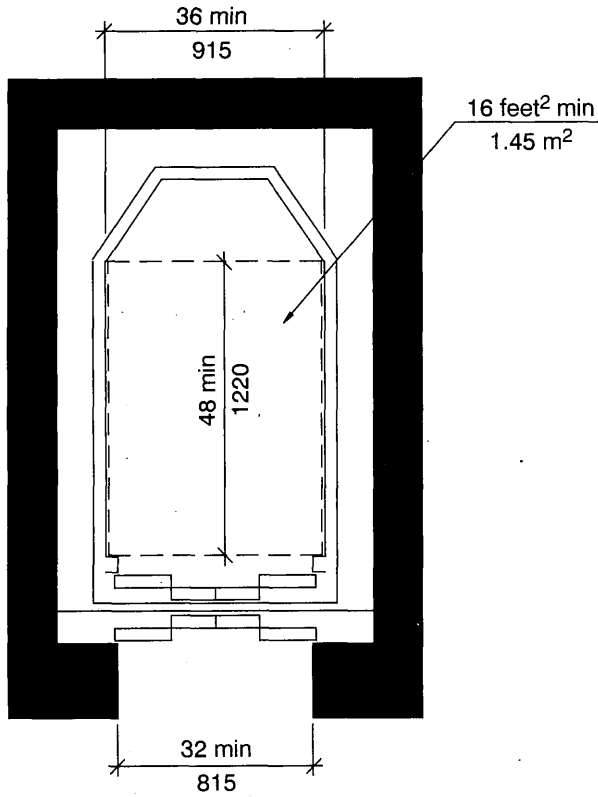

Fig. 407.5.5
Existing Car Configurations

Where the panel is changed, it shall comply with Section 407.2.11.3.

407.5.6.4 Operating Panels. Where a new car operating panel complying with the requirements of Section 407.2.11 is provided, existing car operating panels not complying with Section 407.2.11 are not required to be removed.

407.5.7 Car Position Indicators. Where a new car position indicator is provided, the indicator shall comply with Section 407.2.12.

407.5.8 Identification. Elevators that comply with Section 407.5 shall be clearly identified with the International Symbol of Accessibility complying with Section 703.7, unless all elevators in the building are accessible.

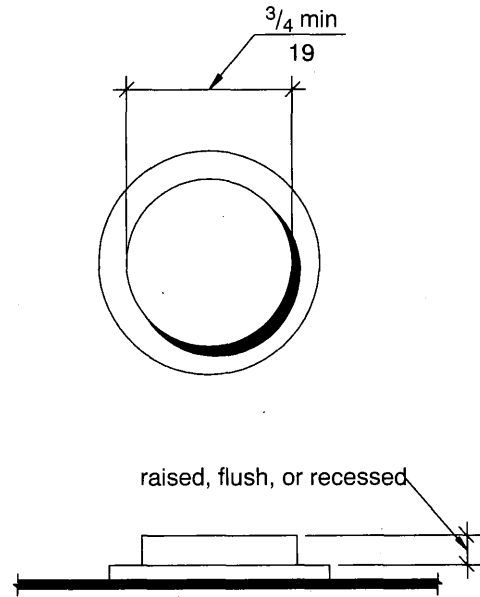

Fig. 407.5.6.1
Elevator Car Control Buttons in Existing Elevators

408 Wheelchair (Platform) Lifts

408.1 General. Wheelchair (platform) lifts shall comply with ASME/ANSI A17.1 and with Sections 302, 305, and 309. Wheelchair (platform) lifts shall not be attendant-operated and shall provide unassisted entry and exit from the lift.

408.2 Doors and Gates. Lifts shall have low energy power-operated doors or gates complying with Section 404.3. Doors and gates shall remain open for 20 seconds minimum. End doors shall be 32 inches (815 mm) minimum clear width. Side doors shall be 42 inches (1065 mm) minimum clear width.

EXCEPTION: Lifts having doors or gates on opposite sides shall be permitted to have manual doors or gates.

Chapter 5. General Site and Building Elements

501 General

501.1 Scope. General site and building elements required to be accessible by the scoping provisions adopted by the administrative authority shall comply with the applicable provisions of this chapter.

502 Parking Spaces

502.1 General. Accessible parking spaces shall comply with Section 502.

502.2 Vehicle Spaces. Car and van parking spaces shall be 96 inches (2440 mm) wide minimum and shall have an adjacent access aisle complying with Section 502.3.

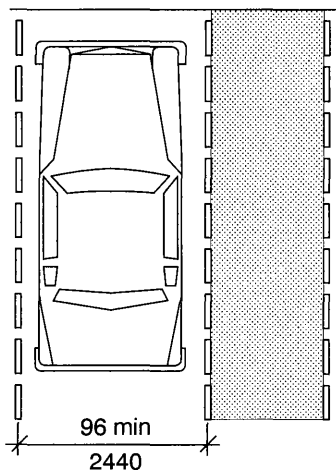

Fig. 502.2
Vehicle Parking Space

502.3 Access Aisle. Access aisles serving parking spaces shall comply with Sections 502.3.1 through 502.3.3. Parking access aisles shall be part of the accessible route to the building or facility entrance and shall comply with Section 402. Two parking spaces shall be permitted to share a common access aisle. Parked vehicle overhangs shall not reduce the clear width of an accessible route.

502.3.1 Width. Access aisles serving car parking spaces shall be 60 inches (1525 mm) wide minimum. Access aisles serving van parking spaces shall be 96 inches (2440 mm) wide minimum.

502.3.2 Length. Access aisles shall extend the full length of the parking spaces they serve.

502.3.3 Marking. Access aisles shall be marked so as to discourage parking in them.

502.4 Floor or Ground Surfaces. Parking spaces and access aisles shall have surface slopes not steeper than 1:48. Access aisles shall be at the same level as the parking spaces they serve.

502.5 Vertical Clearance. Parking spaces for vans shall have a vertical clearance of 98 inches (2490 mm) minimum at the space and along the vehicular route thereto.

502.6 Identification. Where accessible parking spaces are required to be identified by signs, the signs shall include the International Symbol of Accessibility complying with Section 703.7. Such signs shall be 60 inches (1525 mm) minimum above the floor or ground surface of the parking space, measured to the bottom of the sign.

503 Passenger Loading Zones

503.1 General. Accessible passenger loading zones shall comply with Section 503.

503.2 Vehicle Pull-up Space. Passenger loading zones shall provide an access aisle complying with Section 503.3, adjacent and parallel to a vehicle pull-up space.

503.3 Access Aisle. Access aisles serving passenger loading zones shall comply with Section 302 and Sections 503.3.1 through 503.3.3. Access aisles shall be part of the accessible route to the building or facility entrance and shall comply with Section 402.

503.3.1 Width. Access aisles serving vehicle pull-up spaces shall be 60 inches (1525 mm) wide minimum.

503.3.2 Length. Access aisles shall be 20 feet (6100 mm) long minimum.

503.3.3 Marking. Access aisles shall be marked so as to discourage parking in them.

503.4 Floor or Ground Surfaces. Vehicle pull-up spaces in passenger loading zones and access aisles shall have surface slopes not steeper than

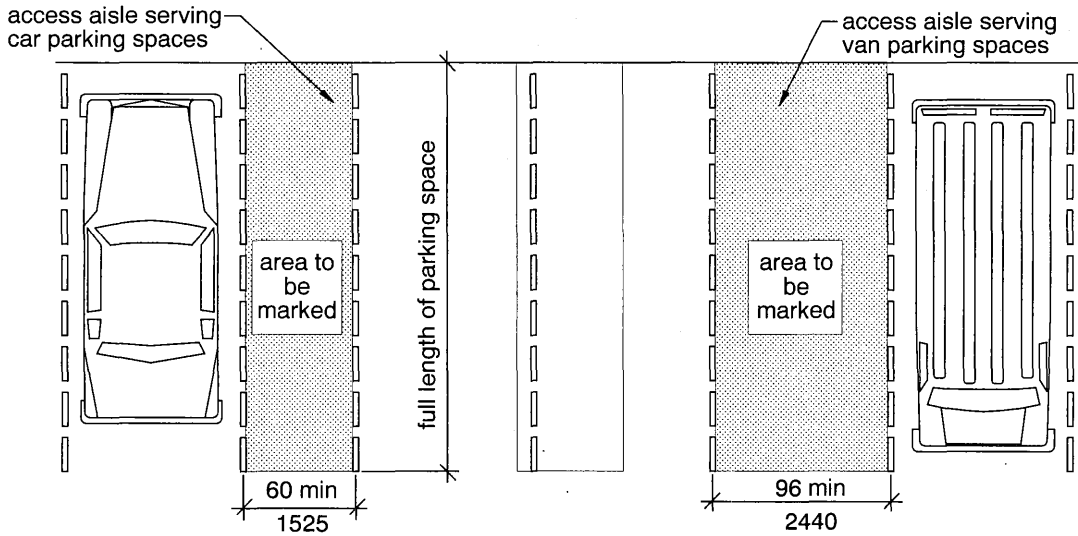

Fig. 502.3
Parking Space Access Aisle

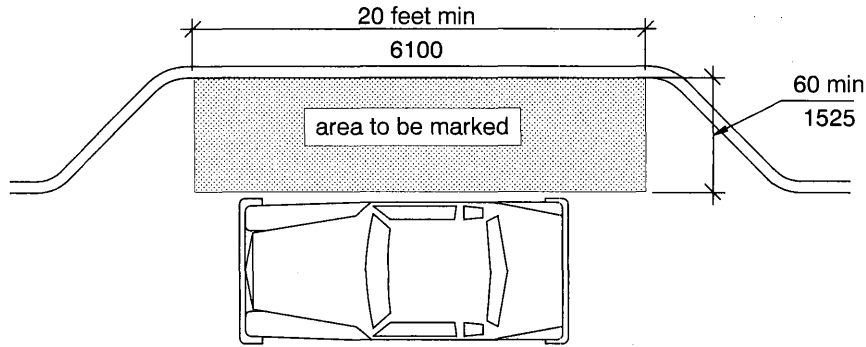

Fig. 503.3
Passenger Loading Zone Access Aisle

1:48. Access aisles shall be at the same level as the vehicle pull-up space they serve.

503.5 Vertical Clearance. Vertical clearance of 114 inches (2895 mm) minimum shall be provided at passenger loading zones and along vehicle access routes to such areas from site entrances.

504 Stairways

504.1 General. Accessible stairs shall comply with Section 504.

504.2 Treads and Risers. All steps on a flight of stairs shall have uniform riser heights and uniform tread depth. Risers shall be 4 inches (102 mm) high minimum and 7 inches (180 mm) maximum. Treads shall be 11 inches (280 mm) deep minimum, measured from riser to riser.

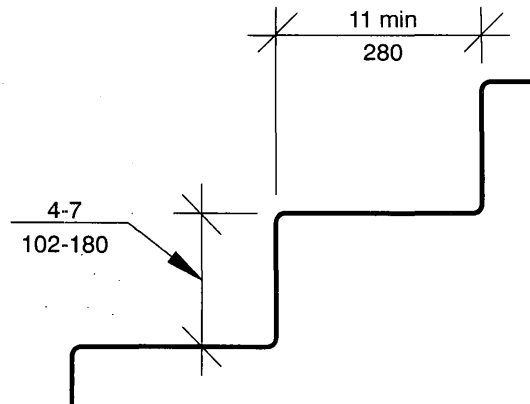

Fig. 504.2
Treads and Risers for Accessible Stairways

504.3 Open Risers. Open risers shall not be permitted.

504.4 Tread Surface. Stair treads shall comply with Section 302.

504.5 Nosings. The radius of curvature at the leading edge of the tread shall be $1/2$ inch (13 mm) maximum. Nosings that project beyond risers shall have the underside of the leading edge curved or beveled. Risers shall be permitted to slope under the tread at an angle of 30 degrees maximum from vertical. The permitted projection of the nosing shall be $1 1/2$ inches (38 mm) maximum beyond the tread below.

504.6 Handrails. Stairs shall have handrails complying with Section 505.

504.7 Outdoor Conditions. Outdoor stairs and outdoor approaches to stairs shall be designed so that water will not accumulate on walking surfaces.

505 Handrails

505.1 General. Handrails required by Section 405 for ramps or Section 504 for stairs shall comply with Section 505.

505.2 Location. Handrails shall be provided on both sides of stairs and ramps.

EXCEPTION: Aisle stairs and aisle ramps provided with a handrail either at the side or within the aisle width.

505.3 Continuity. Handrails shall be continuous within the full length of each stair flight or ramp run. Inside handrails on switchback or dogleg stairs or ramps shall be continuous between flights or runs. Other handrails shall comply with Sections 505.10 and 307.

EXCEPTION: Handrails in aisles serving seating.

505.4 Height. Top of gripping surfaces of handrails shall be 34 inches (865 mm) minimum and 38 inches (965 mm) maximum vertically above stair nosings and ramp surfaces. Handrails shall be at a consistent height above stair nosings and ramp surfaces.

505.5 Clearance. Clear space between handrail and wall shall be $1 1/2$ inches (38 mm) minimum.

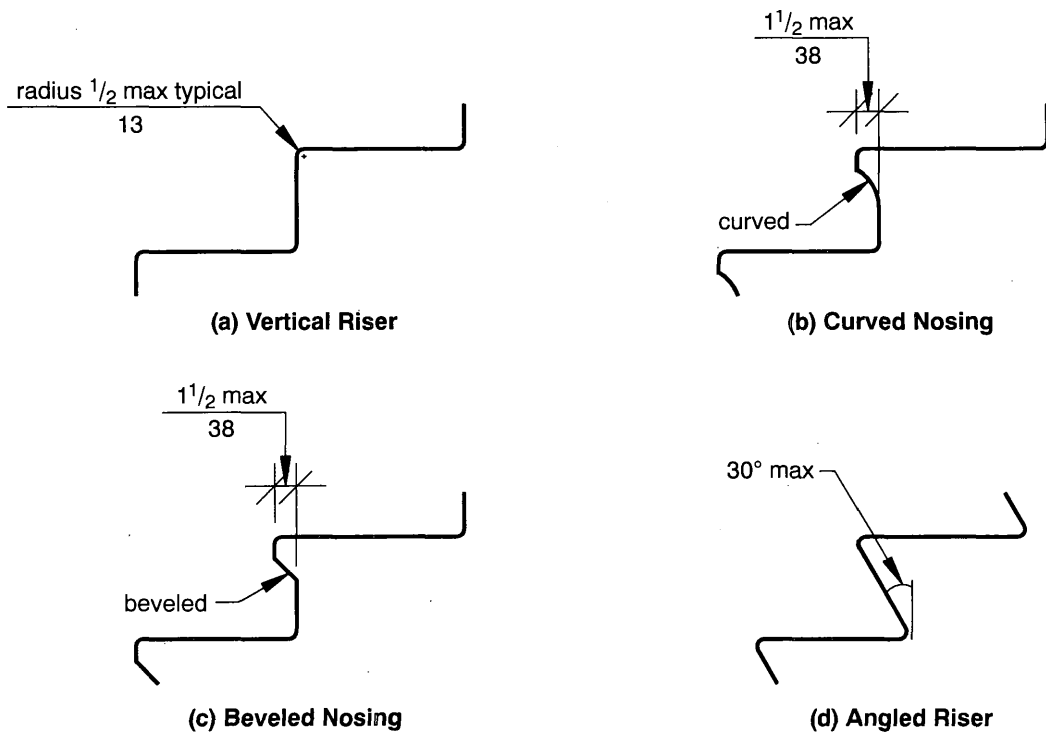

Fig. 504.5
Stair Nosings

505.6 Gripping Surface. Gripping surfaces shall be continuous, without interruption by newel posts, other construction elements, or obstructions.

EXCEPTION: Handrail brackets or balusters attached to the bottom surface of the handrail shall not be considered obstructions provided they comply with the following criteria:

- 1) not more than 20 percent of the handrail length is obstructed,
- 2) horizontal projections beyond the sides of the handrail occur 2 1/2 inches (64 mm) minimum below the bottom of the handrail, and
- 3) edges have a 1/8 inch (3.2 mm) minimum radius.

505.7 Cross Section. Handrails shall have a circular cross section with an outside diameter of 1 1/4 inch (32 mm) minimum and 2 inches (51 mm) maximum, or shall provide equivalent graspability complying with Section 505.7.1.

505.7.1 Non-Circular Cross Sections. Handrails with other shapes shall be permitted provided they have a perimeter dimension of 4 inches (102 mm) minimum and 6 1/4 inches (160 mm) maximum, and provided their largest cross-section dimension is 2 1/4 inches (57 mm) maximum.

505.8 Surfaces. Handrails, and any wall or other surfaces adjacent to them, shall be free of any sharp

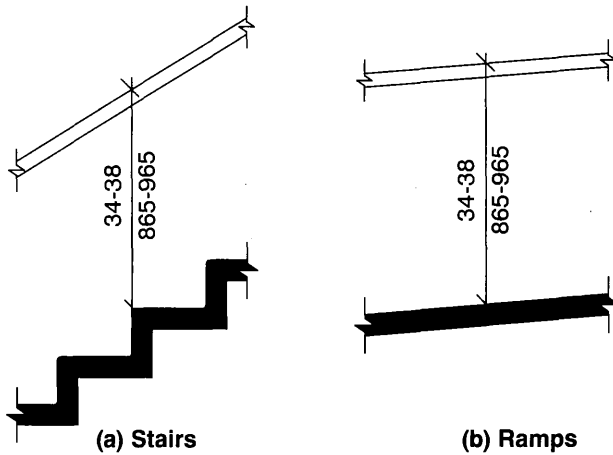

Fig. 505.4
Handrail Height

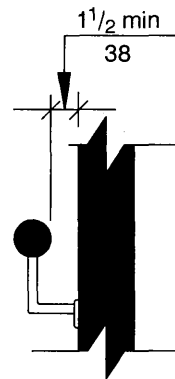

Fig. 505.5
Handrail Clearance

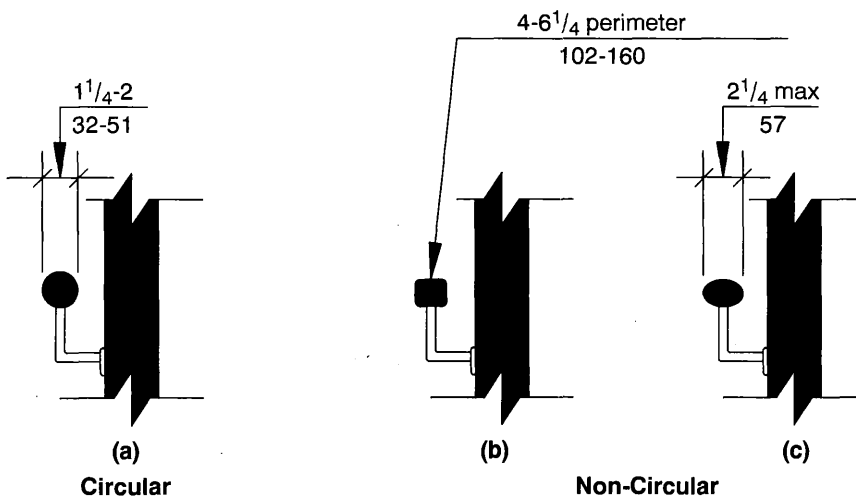

Fig. 505.7
Handrail Cross Section

or abrasive elements. Edges shall have $\frac{1}{8}$ inch (3.2 mm) minimum radius.

505.9 Fittings. Handrails shall not rotate within their fittings.

505.10 Handrail Extensions. Handrails for stairs and ramps shall have extensions complying with Sections 505.10.1 through 505.10.3.

EXCEPTIONS:

1. Continuous handrails at the inside turn of stairs and ramps.
2. Extensions are not required for handrails in aisles serving seating where the handrails are discontinuous to provide access to seating and to permit crossovers within the aisle.

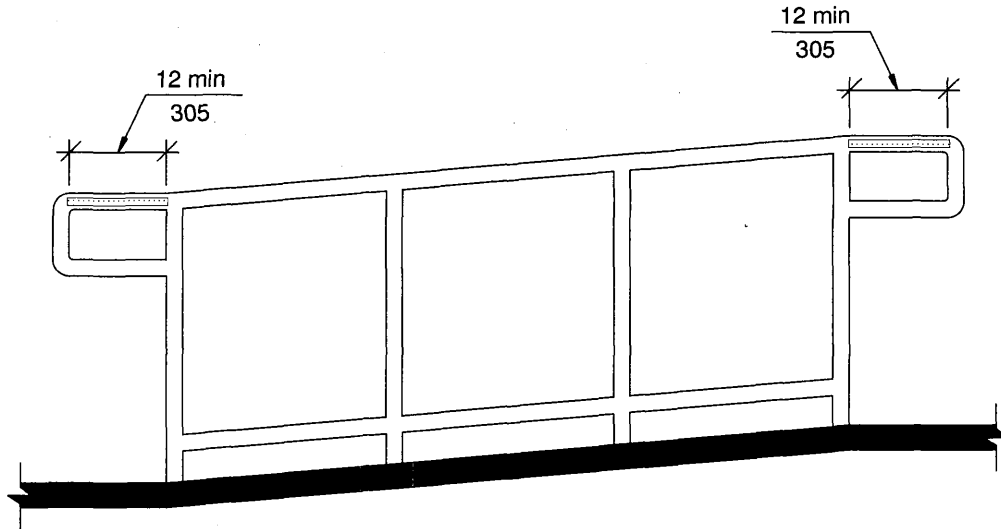

Fig. 505.10.1
Top and Bottom Handrail Extensions at Ramps

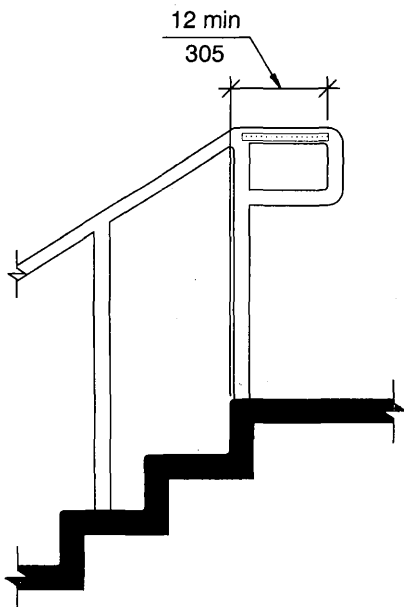

Fig. 505.10.2
Top Handrail Extensions at Stairs

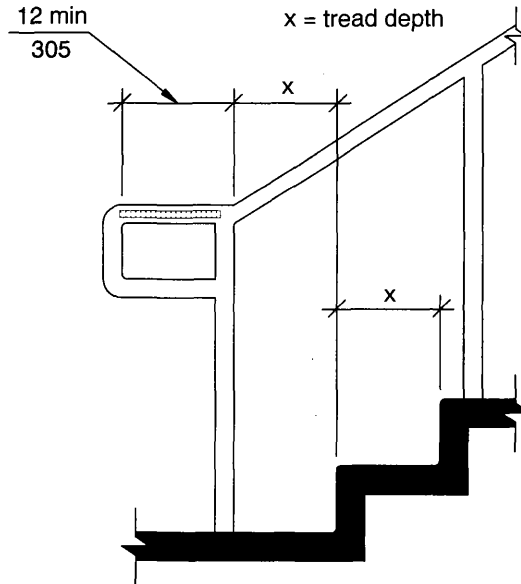

Fig. 505.10.3
Bottom Handrail Extensions at Stairs

505.10.1 Top and Bottom Extension at Ramps. Ramp handrails shall extend horizontally 12 inches (305 mm) minimum beyond the top and bottom of ramp runs. Such extension shall return to a wall, guard, or the walking surface, or shall be continuous to the handrail of an adjacent ramp run.

505.10.2 Top Extension at Stairs. At the top of a stair flight, handrails shall extend horizontally above the landing for 12 inches (305 mm) minimum beginning directly above the first riser nosing. Such extension shall return to a wall, guard, or the walking surface, or shall be continuous to the handrail of an adjacent stair flight.

505.10.3 Bottom Extension at Stairs. At the bottom of a stair flight, handrails shall extend at the slope of the stair flight for a horizontal distance equal to one tread depth beyond the last riser nosing. Such extension shall continue with a horizontal extension or shall be continuous to the handrail of an adjacent stair flight or shall return to a wall, guard, or the walking surface. If provided at the bottom of a stair flight, a horizontal extension of a handrail shall be 12 inches (305 mm) long minimum and a height equal to that of the sloping portion of the handrail as measured above the stair nosings. Such extension shall return to a wall, guard, or the walking

surface, or shall be continuous to the handrail of an adjacent stair flight.

506 Windows

Accessible windows shall have operable parts complying with Section 309.

507 Bus Stop Pads

507.1 General. Where a bus stop pad is provided at bus stops, bays, or other areas where a lift or ramp is to be deployed, it shall comply with Section 507.

507.2 Surface. The pad shall have a firm, stable surface.

507.3 Size. The minimum clear length shall be 96 inches (2440 mm), measured perpendicular from the curb or edge of the vehicle roadway. The minimum clear width shall be 60 inches (1525 mm), measured parallel to the curb or edge of the vehicle roadway.

507.4 Slope. The slope of the pad parallel to the roadway shall be the same as the roadway. The slope of the pad perpendicular to the roadway shall not be steeper than 1:48.

507.5 Location. Pads shall adjoin an accessible route complying with Sections 307 and 402.

Chapter 6. Plumbing Elements and Facilities

601 General

601.1 Scope. Plumbing elements and facilities required to be accessible by scoping provisions adopted by the administrative authority shall comply with the applicable provisions of this chapter.

602 Drinking Fountains and Water Coolers

602.1 General. Accessible fixed drinking fountains and water coolers shall comply with Section 602.

602.2 Clear Floor or Ground Space. A clear floor or ground space complying with Section 305 shall be provided.

602.2.1 Forward Approach. Where a forward approach is provided, the clear floor or ground space shall be centered on the unit and shall include knee and toe clearance complying with Section 306.

602.2.2 Parallel Approach. Where a parallel approach is provided, the clear floor or ground space is centered on the unit.

602.3 Operable Parts. Operable parts shall comply with Section 309.

602.4 Spout Height. Spout outlets shall be 36 inches (915 mm) maximum above the floor or ground.

602.5 Spout Location. Units with a parallel approach shall have the spout $3\frac{1}{2}$ inches (89 mm) maximum from the front edge of the unit, including bumpers. Units with a forward approach shall have the spout 15 inches (380 mm) minimum from the vertical support and 5 inches (125 mm) maximum from the front edge of the unit, including bumpers.

602.6 Water Flow. The spout shall provide a flow of water 4 inches (102 mm) high minimum to allow the insertion of a cup or glass under the flow of water. The angle of the water stream from spouts within 3 inches (76 mm) of the front of the unit shall be 30 degrees maximum. The angle of the water stream from spouts between 3 inches (76 mm) and 5 inches (125 mm) from the front of the unit shall be 15 degrees maximum. The angle of the water stream shall be measured horizontally, relative to the front face of the unit.

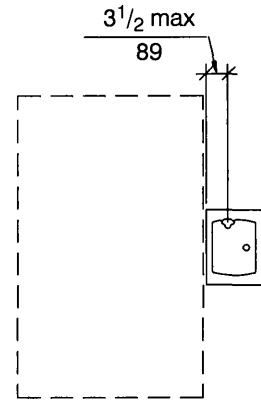

(a) Parallel Approach

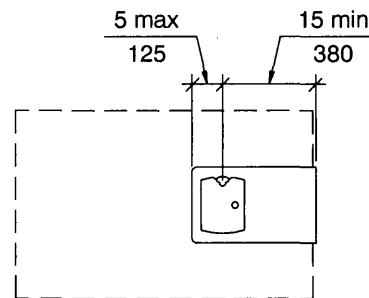

(b) Forward Approach

Fig. 602.5
Drinking Fountain Spout Location

602.7 Protruding Objects. Units shall comply with Section 307.

603 Toilet and Bathing Rooms

603.1 General. Accessible toilet and bathing rooms shall comply with Section 603.

603.2 Clearances.

603.2.1 Wheelchair Turning Space. A wheelchair turning space complying with Section 304 shall be provided within the room.

603.2.2 Overlap. Clear floor or ground spaces, clearances at fixtures, and wheelchair turning spaces shall be permitted to overlap.

603.2.3 Doors. Doors shall not swing into the clear floor or ground space or clearance for any fixture.

EXCEPTION: Where the room is for individual use and a clear floor or ground space complying with Section 305.3 is provided within the room, beyond the arc of the door swing.

603.3 Mirrors. Mirrors shall be mounted with the bottom edge of the reflecting surface 40 inches (1015 mm) maximum above the floor or ground.

603.4 Coat Hooks and Shelves. Coat hooks provided within toilet rooms shall accommodate a forward reach or side reach complying with Section 308. Where provided, a fold-down shelf shall be 40 inches (1015 mm) minimum and 48 inches (1220 mm) maximum above the floor or ground.

604 Water Closets and Toilet Compartments

604.1 General. Accessible water closets and toilet compartments shall comply with Section 604.

604.2 Location. The water closet shall be positioned with a wall or partition to the rear and to one side. The centerline of the water closet shall be 16 inches (405 mm) minimum to 18 inches (455 mm) maximum from the side wall or partition, except that the water closet shall be centered in the ambulatory accessible compartment specified in Section 604.8.2.

604.3 Clearance.

604.3.1 Size. Clearance around the water closet shall be 60 inches (1525 mm) minimum, measured perpendicular from the side wall, and 56 inches (1420 mm) minimum, measured perpendicular from the rear wall. No other fixtures

or obstructions shall be within the water closet clearance.

604.3.2 Overlap. The clearance around the water closet shall be permitted to overlap the fixture, associated grab bars, tissue dispensers, accessible routes, and clear floor or ground space, or clearances at other fixtures and the wheelchair turning space.

604.4 Height. The top of water closet seats shall be 17 inches (430 mm) minimum and 19 inches (485 mm) maximum above the floor or ground. Seats shall not return automatically to a lifted position.

604.5 Grab Bars. Grab bars for water closets shall comply with Section 609. Grab bars shall be provided on the rear wall and on the side wall closest to the water closet.

604.5.1 Side Wall. Side wall grab bar shall be 42 inches (1065 mm) long minimum, 12 inches (305 mm) maximum from the rear wall and extending 54 inches (1370 mm) minimum from the rear wall.

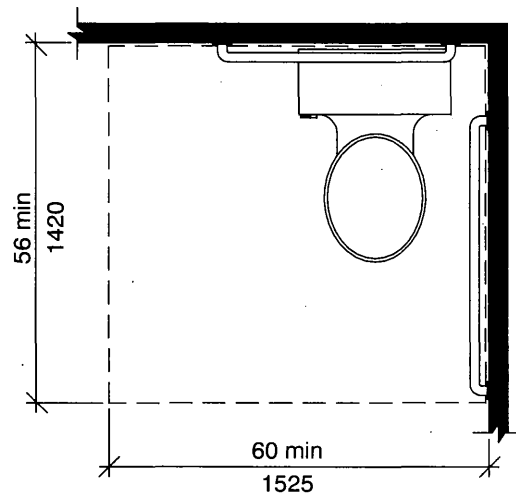

Fig. 604.3.1
Size of Clearance for Water Closet

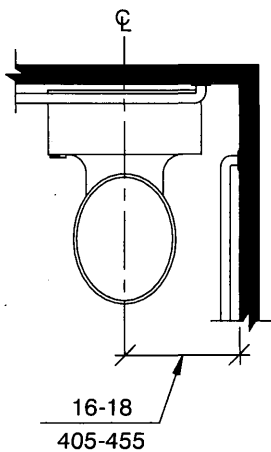

Fig. 604.2
Water Closet Location

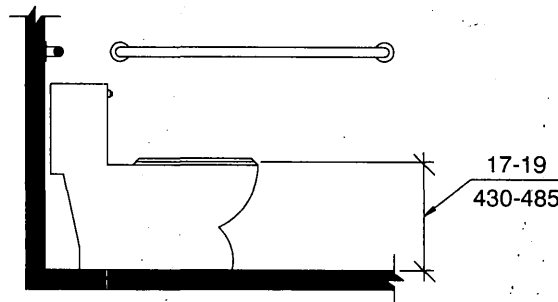

Fig. 604.4
Height of Water Closet

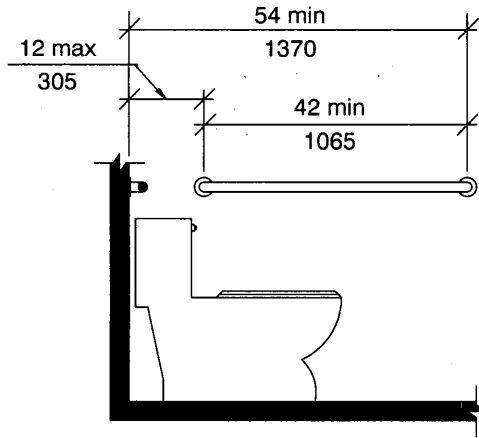

Fig. 604.5.1
Side Wall Grab Bar for Water Closet

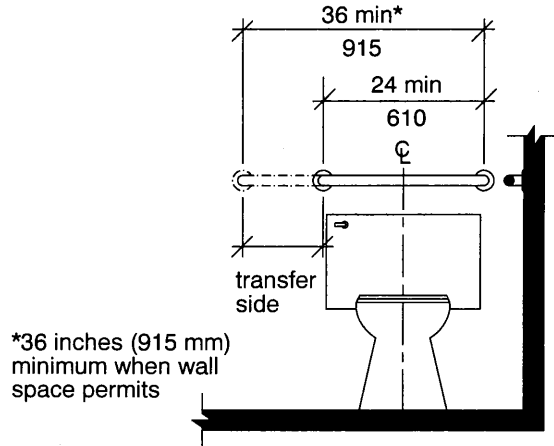
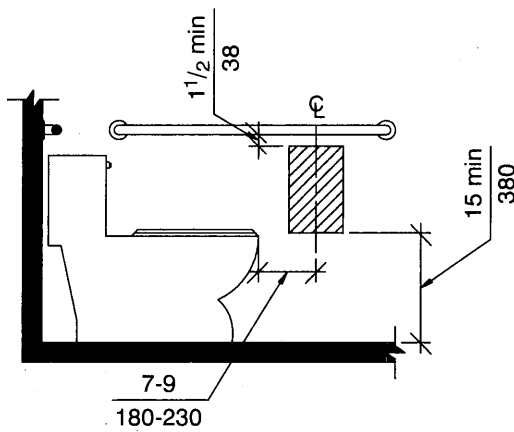
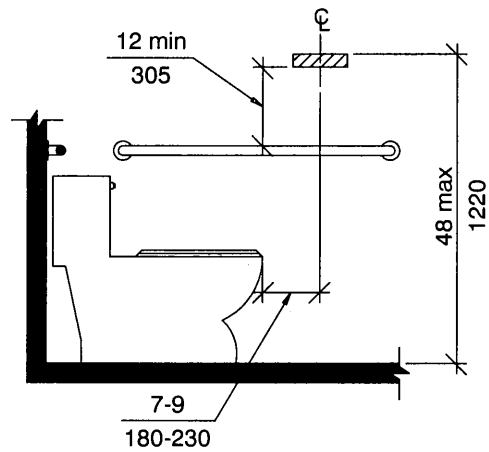

Fig. 604.5.2
Rear Wall Grab Bar for Water Closet



(a) Below Grab Bar



(b) Above Grab Bar

Fig. 604.7
Dispenser Location

604.5.2 Rear Wall. The rear wall grab bar shall be 24 inches (610 mm) long minimum, centered on the water closet. Where space permits, the bar shall be 36 inches (915 mm) long minimum, with the additional length provided on the transfer side of the water closet.

604.6 Flush Controls. Flush controls shall be hand operated or automatic. Hand-operated flush controls shall comply with Section 309.

604.7 Dispensers. Toilet paper dispensers shall comply with Section 309.4 and shall be 7 inches (180 mm) minimum and 9 inches (230 mm) maximum in front of the water closet. The outlet of the dispenser shall be 15 inches (380 mm) minimum and 48 inches (1220 mm) maximum above the floor or ground. There shall be a clearance of 1 1/2 inches (38 mm) minimum below and 12 inches (305 mm) minimum above the grab bar. Dispensers shall not

be of a type that control delivery, or that do not allow continuous paper flow.

604.8 Toilet Compartments. Accessible toilet compartments shall comply with Sections 604.8.1 through 604.8.5. Compartments containing more than one plumbing fixture shall comply with Section 603. Water closets in accessible toilet compartments shall comply with Sections 604.1 through 604.7.

604.8.1 Wheelchair Accessible Compartments.

604.8.1.1 Size. Wheelchair accessible compartments shall be 60 inches (1525 mm) wide minimum measured perpendicular to the side wall, and 56 inches (1420 mm) deep minimum for wall hung water closets and 59 inches (1500 mm) deep

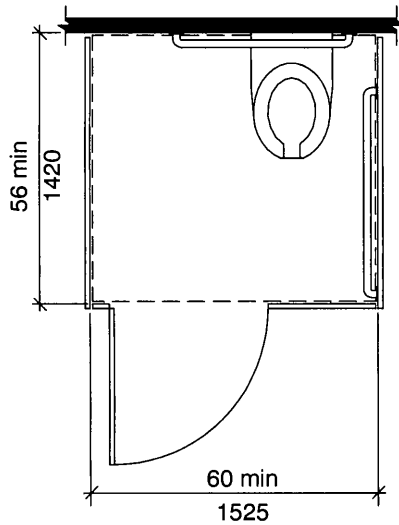

(a) Wall-Hung Water Closet

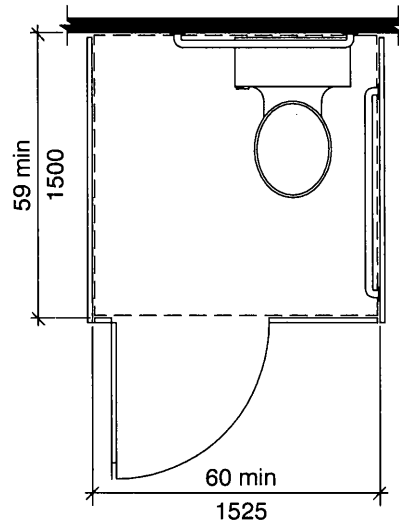

(b) Floor-Mounted Water Closet

Fig. 604.8.1.1
Wheelchair Accessible Toilet Compartments

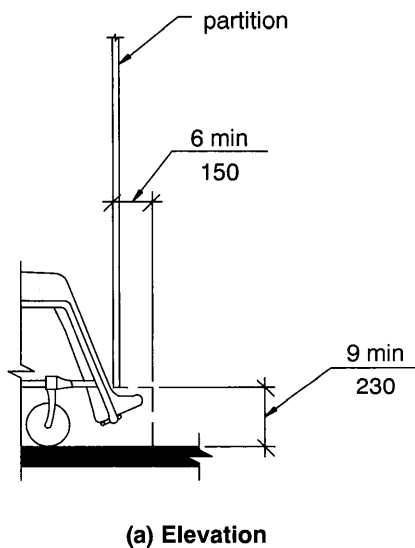

(a) Elevation

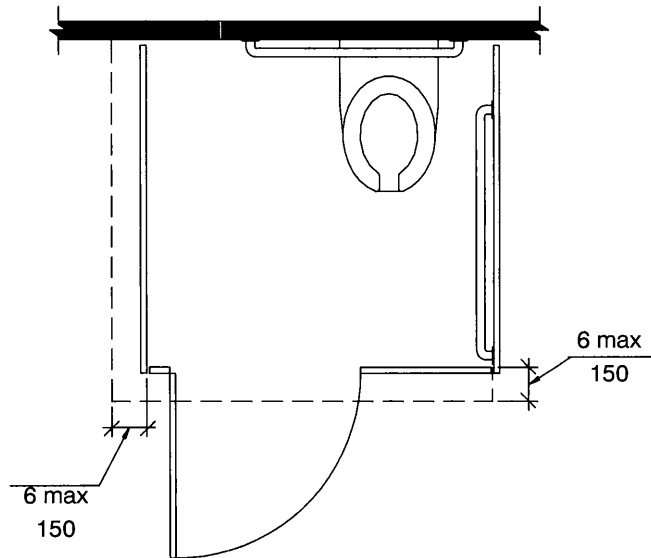

(b) Plan

Fig. 604.8.1.4
Toilet Compartment Toe Clearance

minimum for floor mounted water closets, measured perpendicular to the rear wall.

604.8.1.2 Doors. Compartment doors shall not swing into the minimum required compartment area.

604.8.1.3 Approach. Compartment arrangements shall be permitted for left-hand or right-hand approach to the water closet.

604.8.1.4 Toe Clearance. In wheelchair accessible compartments, the front partition and at least one side partition shall provide a toe clearance complying with Section 306.2 and extending 6 inches (150 mm) deep beyond the compartment-side face of the partition, exclusive of partition support members. Toe clearance at the front of the partition is not required in a compartment greater than 62 inches (1575 mm) deep with a wall-hung water closet or 65 inches

(1650 mm) deep with a floor-mounted water closet. Toe clearance at the side partition is not required in a compartment greater than 66 inches (1675 mm) wide.

604.8.2 Ambulatory Accessible Compartments. Ambulatory accessible compartments shall be 60 inches (1525 mm) deep minimum and 36 inches (915 mm) wide. Compartment doors shall not swing into the minimum required compartment area.

604.8.3 Doors. Toilet compartment doors shall comply with Section 404, except that if the approach is to the latch side of the compartment door, the clearance between the door side of the compartment and any obstruction shall be 42 inches (1065 mm) minimum. The door shall be hinged 4 inches (102 mm) maximum from the adjacent wall or partition farthest from the water closet. The door shall be self-closing. A door pull complying with Section 404.2.7 shall be placed on both sides of the door near the latch.

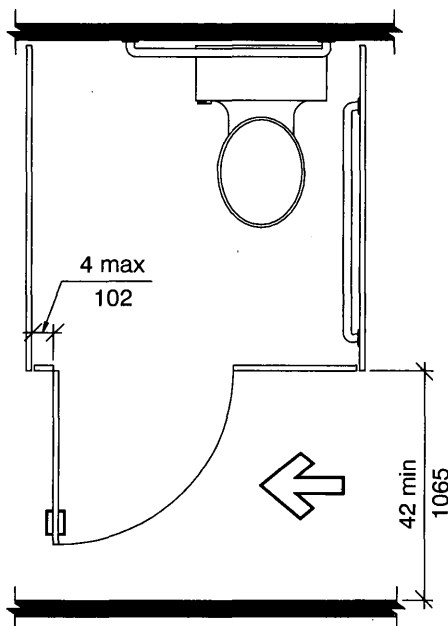

Fig. 604.8.3
Toilet Compartment Doors

604.8.4 Grab Bars. Grab bars shall comply with Section 609.

604.8.4.1 Wheelchair Accessible Compartments. A side-wall grab bar complying with Section 604.5.1 shall be provided on the wall closest to the water closet, and a rear-wall grab bar complying with Section 604.5.2 shall be provided.

604.8.4.2 Ambulatory Accessible Compartments. A side-wall grab bar complying with Section 604.5.1 shall be provided on both sides of the compartment.

604.8.5 Coat Hooks and Shelves. Coat hooks provided within toilet compartments shall be 48 inches (1220 mm) maximum above the floor or ground. Where provided, a fold-down shelf shall be 40 inches (1015 mm) minimum and 48 inches (1220 mm) maximum above the floor or ground.

605 Urinals

605.1 General. Accessible urinals shall comply with Section 605.

605.2 Height. Urinals shall be of the stall type or shall be of the wall-hung type with the rim at 17 inches (430 mm) maximum above the floor or ground.

605.3 Clear Floor or Ground Space. A clear floor or ground space complying with Section 305 positioned for forward approach shall be provided.

605.4 Flush Controls. Flush controls shall be hand operated or automatic. Hand-operated flush controls shall comply with Section 309.

606 Lavatories and Sinks

606.1 General. Accessible lavatories and sinks shall comply with Section 606.

606.2 Clear Floor or Ground Space. A clear floor or ground space complying with Section 305.3, positioned for forward approach, shall be provided. Knee and toe clearance complying with Section 306 shall be provided.

EXCEPTIONS:

1. A parallel approach shall be permitted to a kitchen sink in a space where a cook top or conventional range is not provided.
2. The dip of the overflow shall not be considered in determining knee and toe clearances.

606.3 Height and Clearances. The front of lavatories and sinks shall be 34 inches (865 mm) maximum above the floor or ground, measured to the higher of the fixture rim or counter surface.

606.4 Faucets. Faucets shall comply with Section 309. Hand-operated, self-closing faucets shall remain open for 10 seconds minimum.

606.5 Bowl Depth. Sinks shall be 6¹/₂ inches (165 mm) deep maximum. Multiple compartment sinks shall have at least one compartment complying with this requirement.

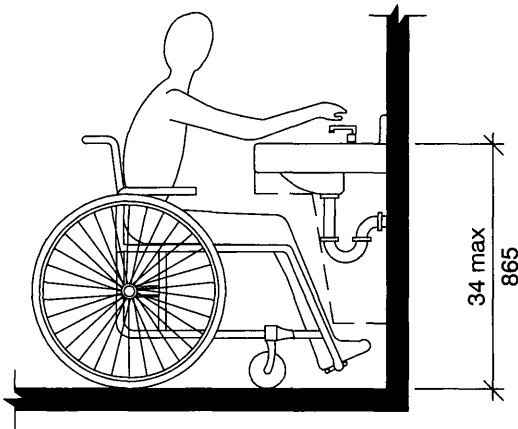

Fig. 606.3
Height of Lavatories and Sinks

606.6 Exposed Pipes and Surfaces. Water supply and drain pipes under lavatories and sinks shall be insulated or otherwise configured to protect against contact. There shall be no sharp or abrasive surfaces under lavatories and sinks.

607 Bathtubs

607.1 General. Accessible bathtubs shall comply with Section 607.

607.2 Clearance. Clearance in front of bathtubs shall extend the length of the bathtub and shall be 30 inches (760 mm) wide minimum. A lavatory complying with Section 606 shall be permitted at the foot end of the clearance. Where a permanent seat is provided at the head end of the bathtub, the clear-

ance shall extend a minimum of 12 inches (305 mm) beyond the wall at the head end of the bathtub.

607.3 Seat. A permanent seat at the head end of the bathtub or a removable in-tub seat shall be provided. Seats shall comply with Section 610.

607.4 Grab Bars. Grab bars shall comply with Sections 607.4 and 609.

607.4.1 Bathtubs With Permanent Seats. For bathtubs with permanent seats, grab bars complying with Sections 607.4.1.1 and 607.4.1.2 shall be provided.

607.4.1.1 Back Wall. Two grab bars shall be provided on the back wall, one complying with Section 609.4 and other 9 inches (230 mm) above the rim of the bathtub. Each grab bar shall be 15 inches (380 mm) maximum from the head end wall and 12 inches (305 mm) maximum from the foot end wall.

607.4.1.2 Foot End Wall. A grab bar 24 inches (610 mm) long minimum shall be provided on the foot end wall at the front edge of the bathtub.

607.4.2 Bathtubs Without Permanent Seats. For bathtubs without permanent seats, grab bars complying with Sections 607.4.2.1 through 607.4.2.3 shall be provided.

607.4.2.1 Back Wall. Two grab bars shall be provided on the back wall, one complying with Section 609.4 and other 9 inches (230 mm) above the rim of the bathtub. Each grab bar shall be 24 inches (610 mm)

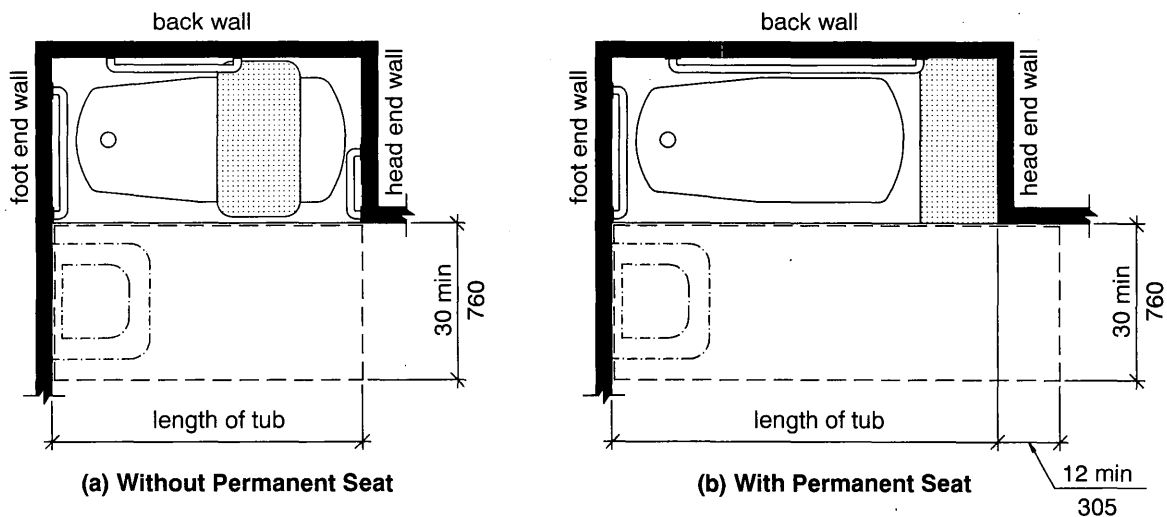

Fig. 607.2
Clearance for Bathtubs

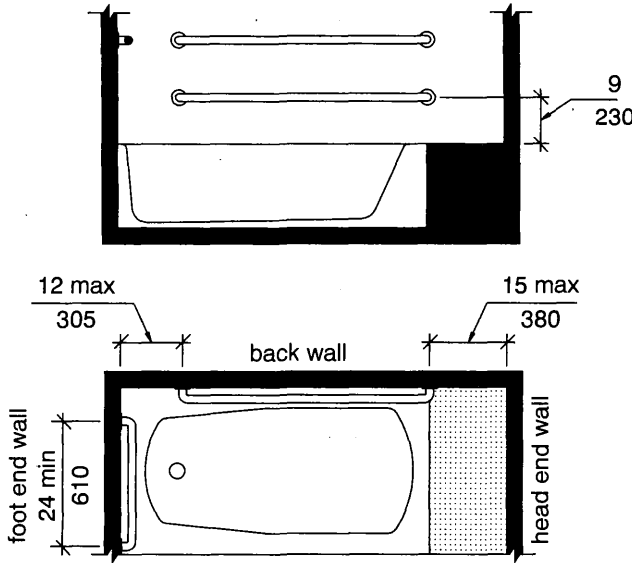

Fig. 607.4.1

Grab Bars for Bathtubs with Permanent Seats

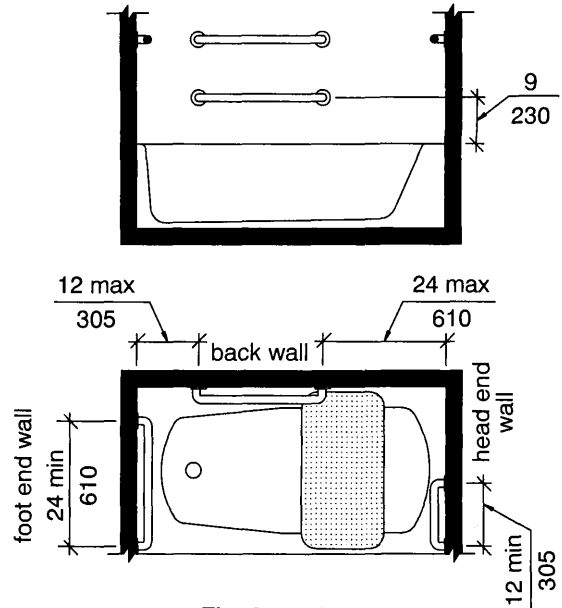

Fig. 607.4.2

Grab Bars for Bathtubs without Permanent Seats

long minimum and shall be 24 inches (610 mm) maximum from the head end wall and 12 inches (305 mm) maximum from the foot end wall.

607.4.2.2 Foot End Wall. A grab bar 24 inches (610 mm) long minimum shall be provided on the foot end wall at the front edge of the bathtub.

607.4.2.3 Head End Wall. A grab bar 12 inches (305 mm) long minimum shall be provided on the head end wall at the front edge of the bathtub.

607.5 Controls. Controls, other than drain stoppers, shall be on an end wall. Controls shall be between the bathtub rim and grab bar, and between the open side of the bathtub and the mid-point of the

width of the bathtub. Controls shall comply with Section 309.4.

607.6 Shower Unit. A shower spray unit shall be provided, with a hose 59 inches (1500 mm) long minimum, that can be used as a fixed shower head and as a hand-held shower. If an adjustable-height shower head on a vertical bar is used, the bar shall not obstruct the use of grab bars.

607.7 Bathtub Enclosures. Bathtub enclosures shall not obstruct controls or transfer from wheelchairs onto bathtub seats or into bathtubs. Bathtub enclosures shall not have tracks on the rim of the bathtub.

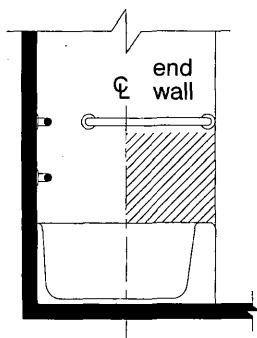

Fig. 607.5

Location of Bathtub Controls

608 Shower Compartments

608.1 General. Accessible shower compartments shall comply with Section 608.

608.2 Size and Clearances.

608.2.1 Transfer-Type Shower Compartments. Transfer-type shower compartments shall be 36 inches (915 mm) wide by 36 inches (915 mm) deep inside finished dimension, measured at the centerpoint of opposing sides, and shall have a minimum 36 inches (915 mm) wide entry on the face of the shower compartment. The clearance in front of the compartment shall be 48 inches (1220 mm) long minimum measured from the control wall and 36 inches (915 mm) wide minimum.

608.2.2 Standard Roll-In-Type Shower Compartment. Roll-in-type shower compart-

ments shall be 30 inches (760 mm) wide minimum by 60 inches (1525 mm) deep minimum, clear inside dimension, measured at the center-point of opposing sides and shall have a minimum 60 inches (1525 mm) wide entry on the face of the shower. A 30 inches (760 mm) wide minimum by 60 inches (1525 mm) long minimum clearance shall be provided adjacent to the open face of the shower compartment. A lavatory complying with Section 606 shall be permitted at the end of the clear space, opposite the shower compartment side where shower controls are positioned.

608.2.3 Alternate Roll-In-Type Shower Compartment. Alternate roll-in shower compartments shall be 36 inches (915 mm) wide and 60 inches (1525 mm) deep minimum. A 36 inch (915 mm) wide minimum entry shall

be provided at one end of the long side of the compartment. The shower unit and controls shall be mounted on the end wall furthest from the compartment entry.

608.3 Grab Bars. Grab bars shall comply with Sections 608.3 and 609 and shall be provided.

608.3.1 Transfer-Type Showers. Grab bars shall be provided across the control wall and on the back wall to a point 18 inches (455 mm) from the control wall.

608.3.2 Roll-In-Type Showers. Grab bars shall be provided on the three walls of the shower. Grab bars shall be 6 inches (150 mm) maximum from the adjacent wall.

EXCEPTIONS:

1. Where a seat is provided in a roll-in shower, grab bars shall not extend over

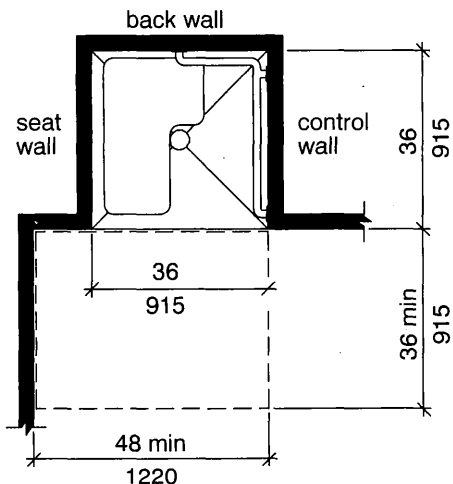

Fig. 608.2.1
Transfer-Type Shower Compartment

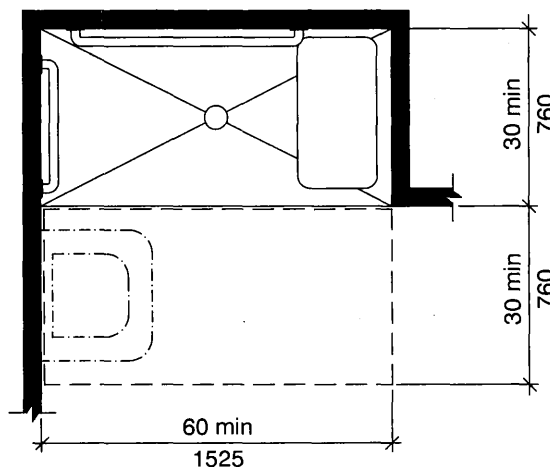

Fig. 608.2.2
Standard Roll-In-Type Shower Compartment

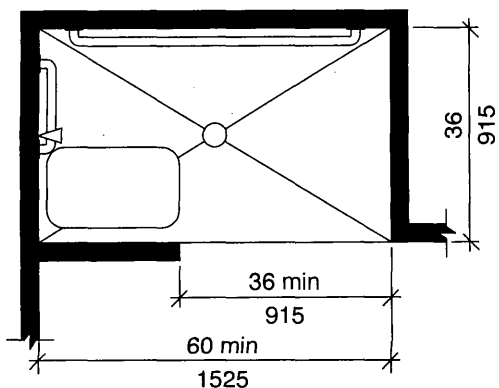

Fig. 608.2.3
Alternate Roll-In-Type Shower Compartment

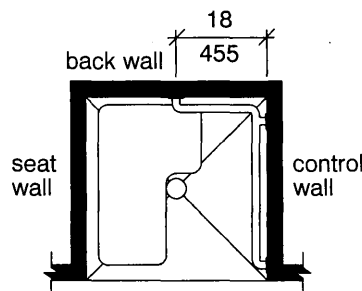

Fig. 608.3.1
Grab Bars in Transfer-Type Showers

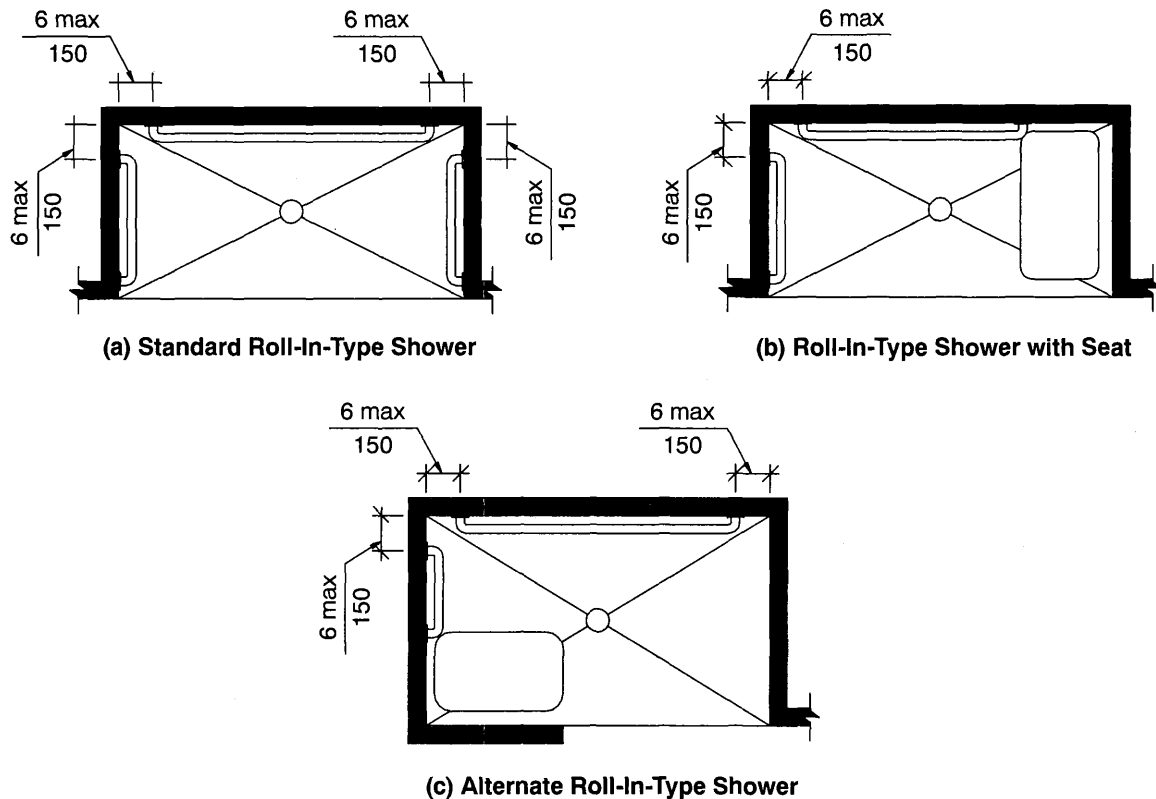

Fig. 608.3.2
Grab Bars in Roll-In-Type Showers

the seat at the control wall and shall not be behind the seat.

2. In alternate roll-in-type showers, grab bars shall not be required on the side wall opposite the control wall and shall not be behind the seat.

608.4 Seats. An attachable or integral seat shall be provided in transfer-type shower compartments. Seats shall comply with Section 610.

608.5 Controls. Shower or bathtub/shower facilities shall deliver water that is thermal shock protected to 120 degrees F (49 degrees C) maximum. Faucets and controls shall comply with Section 309.4. Controls in roll-in showers shall be above the grab bar but no higher than 48 inches (1220 mm) above the shower floor. In transfer-type shower compartments, controls, faucets, and the shower unit shall be on the side wall opposite the seat 38 inches (965 mm) minimum and 48 inches (1220 mm) maximum above the shower floor.

608.6 Shower Unit. A shower spray unit shall be provided, with a hose 59 inches (1500 mm) long minimum, that can be used as a fixed shower head

and as a hand-held shower. In transfer type showers, the controls and shower unit shall be on the control wall within 15 inches (380 mm), left or right, of the centerline of the seat. In roll-in-type showers, shower spray units mounted on the back wall shall be 27 inches (685 mm) maximum from the side wall. If an adjustable-height shower head mounted on a vertical bar is used, the bar shall not obstruct the use of grab bars.

608.7 Thresholds. Shower compartment thresholds shall be $\frac{1}{2}$ inch (13 mm) high maximum and shall comply with Section 303.

608.8 Shower Enclosures. Shower compartment enclosures for shower compartments shall not obstruct controls or obstruct transfer from wheelchairs onto shower seats.

609 Grab Bars

609.1 General. Grab bars in accessible toilet or bathing facilities shall comply with Section 609.

609.2 Size. Grab bars shall have a circular cross section with a diameter of $1\frac{1}{4}$ inch (32 mm) minimum and 2 inches (51 mm) maximum, or shall pro-

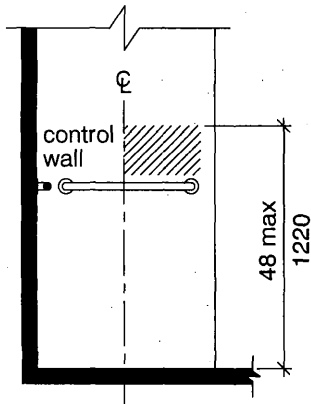

Fig. 608.5
Controls in Transfer-Type Showers

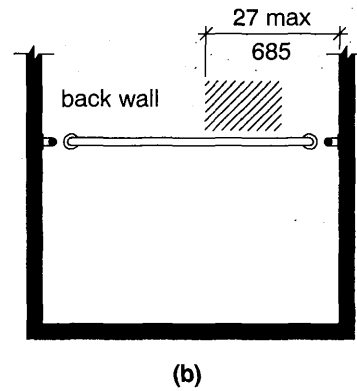
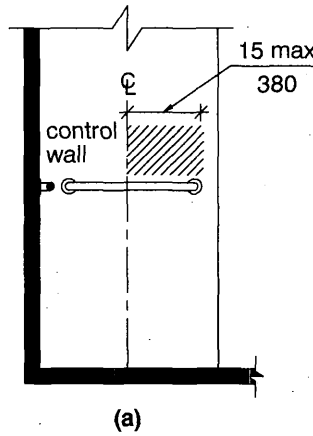

Fig. 608.6
Location of Shower Spray Unit

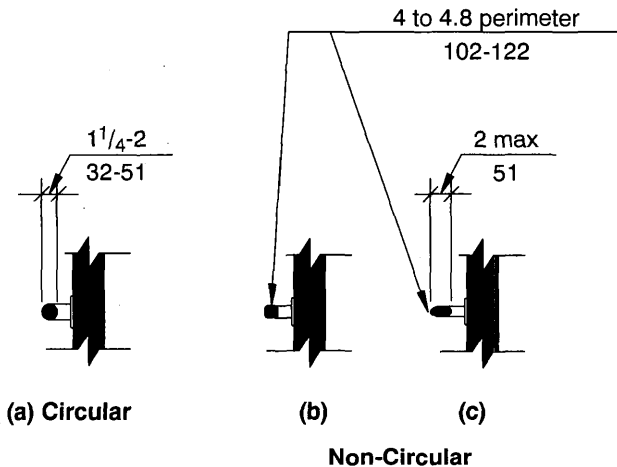

Fig. 609.2
Size of Grab Bars

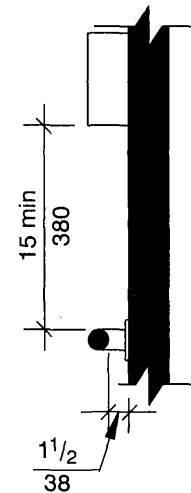

Fig. 609.3
Spacing of Grab Bars

vide equivalent graspability complying with Section 609.2.1.

609.2.1 Non-Circular Cross Sections. Grab bars with other shapes shall be permitted provided they have a perimeter dimension of 4 inches (102 mm) minimum and 4.8 inches (122 mm) maximum and with edges having a $\frac{1}{8}$ inch (3.2 mm) minimum radius.

609.3 Spacing. The space between the wall and the grab bar shall be $1\frac{1}{2}$ inches (38 mm). The space between the grab bar and objects below and at the ends shall be $1\frac{1}{2}$ inches (38 mm) minimum. The space between the grab bar and projecting objects above shall be 15 inches (380 mm) minimum.

EXCEPTION: The space between the grab bars and shower controls, shower fittings, and other grab bars above shall be $1\frac{1}{2}$ inches (38 mm) minimum.

609.4 Position of Grab Bars. Grab bars shall be mounted in a horizontal position, 33 inches (840 mm) minimum and 36 inches (915 mm) maximum above the floor.

EXCEPTION: Height of grab bars on the back wall of a bathtub shall comply with Sections 607.4.1.1 and 607.4.2.1.

609.5 Surface Hazards. Grab bars and any wall or other surfaces adjacent to grab bars shall be free of sharp or abrasive elements. Edges shall have a radius of $\frac{1}{8}$ inch (3.2 mm) minimum.

609.6 Fittings. Grab bars shall not rotate within their fittings.

609.7 Installation. Grab bars shall be installed in any manner that provides a gripping surface at the locations specified in this standard and that does not obstruct the clear floor space.

609.8 Structural Strength. Allowable stresses in bending, shear, and tension shall not be exceeded for materials used where a vertical or horizontal force of 250 pounds (1112 N) is applied at any point on the grab bar, fastener mounting device, or supporting structure.

610 Seats

610.1 General. Seats in accessible bathtubs and shower compartments shall comply with Section 610.

610.2 Bathtub Seats. A removable in-tub seat shall be 15 inches (380 mm) minimum and 16 inches (405 mm) deep maximum, and shall be capable of secure placement. A permanent seat shall be 15 inches (380 mm) deep minimum and be positioned at the head end of the bathtub. The top of the seat shall be 17 inches (430 mm) minimum and 19 inches (485 mm) maximum above the bathroom floor.

610.3 Shower Compartment Seats. Where a seat is provided in a roll-in shower compartment, it shall be a folding type and shall be on the wall adjacent to the controls. Seats shall be L-shaped or rectangular.

The top of the seat shall be 17 inches (430 mm) minimum and 19 inches (485 mm) maximum above the bathroom floor. In a transfer-type shower, the seat shall extend from the back wall to a point within 3 inches (76 mm) of the compartment entry. In a roll-in-type shower, the seat shall extend from the control wall to a point within 3 inches (76 mm) of the minimum required seat wall width.

610.3.1 Rectangular Seats. The rear edge of a rectangular seat shall be 2 1/2 inches (64 mm) maximum from the seat wall, and the front edge 15 inches (380 mm) minimum and 16 inches (405 mm) maximum from the seat wall. In a transfer-type shower the side edge of a rectangular seat shall be 1 1/2 inches (38 mm) maximum. In a roll-in-type shower, the side edge of a rectangular seat shall be 1 1/2 inches (38 mm) maximum from the control wall.

610.3.2 L-Shaped Seats. The rear edge of an L-shaped seat shall be 2 1/2 inches (64 mm) maximum from the seat wall, and the front edge 15 inches (380 mm) minimum and 16 inches (405 mm) maximum from the seat wall. The rear edge of the "L" portion of the seat shall be 1 1/2 inches (38 mm) maximum from the wall and the front edge shall be 14 inches (355 mm) minimum and 15 inches (380 mm) maximum from the wall. The end of the "L" shall be 22 inches (560 mm) minimum and 23 inches (585 mm) maximum from the main seat wall.

610.4 Structural Strength. Allowable stresses in bending, shear, and tension shall not be exceeded

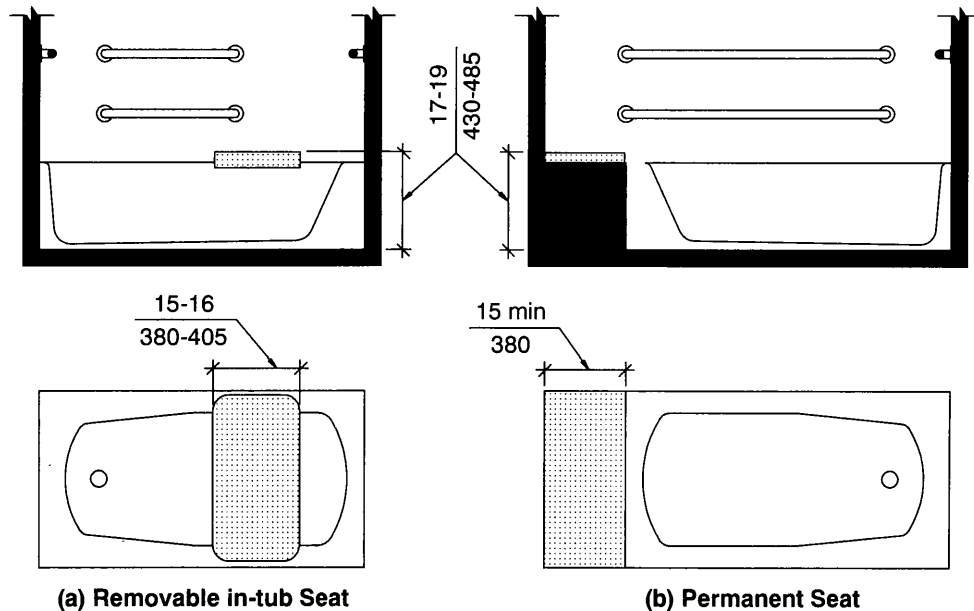

Fig. 610.2
Bathtub Seat

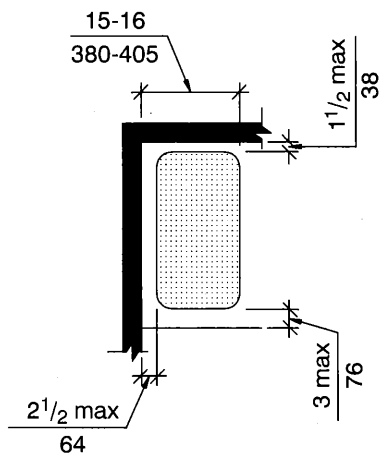

Fig. 610.3.1
Rectangular Shower Compartment Seat

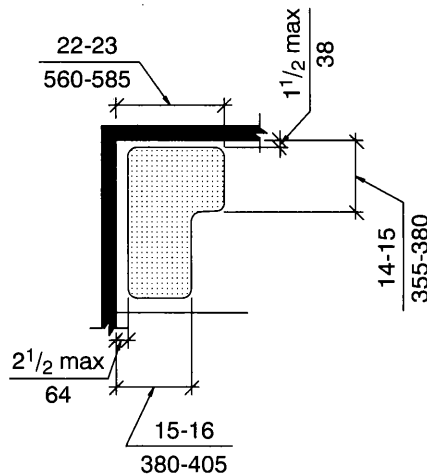

Fig. 610.3.2
L-Shaped Shower Compartment Seat

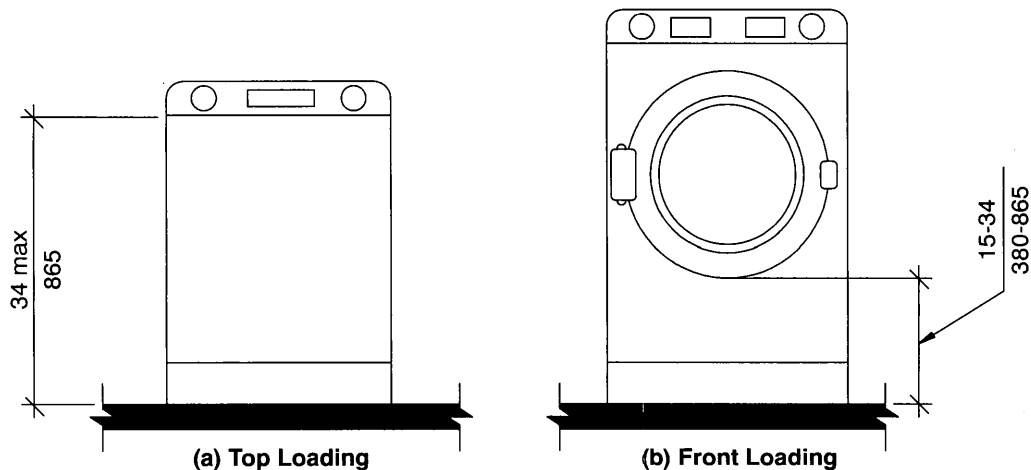

Fig. 611.4
Height of Laundry Equipment

for materials used where a vertical or horizontal force of 250 pounds (1112 N) is applied at any point on the seat, fastener mounting device, or supporting structure.

611 Laundry Equipment

611.1 General. Accessible washing machines and clothes dryers shall comply with Section 611.

611.2 Clear Floor or Ground Space. A clear floor or ground space complying with Section 305 positioned for parallel approach shall be provided. The

clear floor or ground space shall be centered on the appliance.

611.3 Operable Parts. Operable parts, including doors, lint screens, detergent and bleach compartments, shall comply with Section 309.

611.4 Height. Top loading machines shall have the door to the laundry compartment 34 inches (865 mm) maximum above the floor or ground. Front loading machines shall have the bottom of the opening to the laundry compartment 15 inches (380 mm) minimum and 34 inches (865 mm) maximum above the floor or ground.

Chapter 7. Communication Elements and Features

701 General

701.1 Scope. Communications features and elements required to be accessible by the scoping provisions adopted by the administrative authority shall comply with the applicable provisions of this chapter.

702 Alarms

702.1 General. Accessible fire alarm systems shall have audible alarms complying with Section 702.2, and visual alarms complying with Section 702.3.

EXCEPTION: Fire alarm systems in medical care facilities shall be permitted to be modified to suit standard health care alarm practice.

702.2 Audible Alarms. Audible alarms shall produce a sound that exceeds the average ambient sound level in the room or space by at least 15 dBA or exceeds any maximum sound level with a duration of 60 seconds by 5 dBA, whichever is louder. The signal shall consist of a "three pulse" temporal pattern complying with ANSI S3.41, where evacuation of the building is required. Sound levels for alarm signals shall not exceed 120 dBA.

702.3 Visual Alarms. Visual alarms shall comply with Sections 702.3.1 through 702.3.6.

702.3.1 Light Pulse Characteristics.

702.3.1.1 Type. The lamp shall be a xenon strobe type or equivalent.

702.3.1.2 Color. The color shall be clear or nominal white.

702.3.1.3 Flash Rate. The flash rate for an individual appliance shall be 1 Hz minimum and 2 Hz maximum over its rated voltage range.

702.3.1.4 Pulse Duration. The maximum pulse duration shall be two-tenths of one second with a maximum duty cycle of 40 percent. The pulse duration is defined as the time interval between initial and final points of 10 percent of maximum signal.

702.3.2 Dispersion. Light dispersion of wall-mounted appliances shall comply with Table

702.3.2(a). Light dispersion of ceiling-mounted appliances shall comply with Table 702.3.2(b).

702.3.3 Location. Appliances shall comply with Section 702.3.3.1 or 702.3.3.2.

EXCEPTION: Appliances in sleeping rooms shall comply with Section 702.3.6.

702.3.3.1 Wall-Mounted Appliances. Appliances shall be 80 inches (2030 mm) minimum and 96 inches (2440 mm) maximum above the floor or ground, measured to the bottom of the appliance.

EXCEPTION: Wall-mounted appliances which are part of a smoke detector shall be 4 inches (102 mm) minimum and 12 inches (305 mm) maximum below the ceiling, measured to the top of the smoke detector.

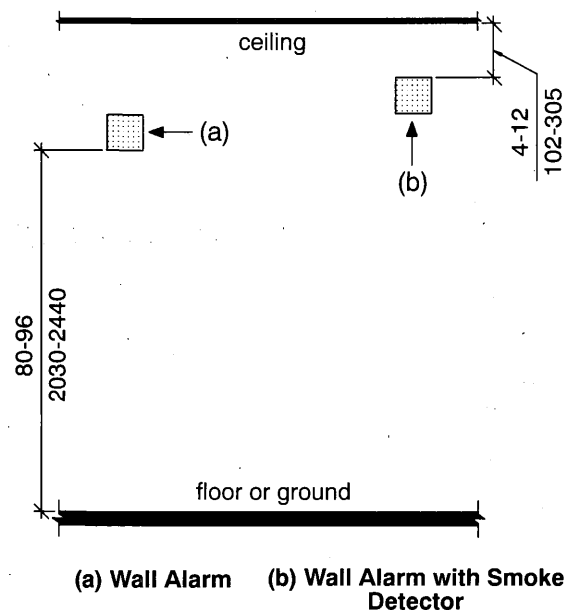

Fig. 702.3.3.1
Location of Wall-Mounted Appliances

702.3.3.2 Ceiling-Mounted Appliances. Appliances shall be on the ceiling. Where ceiling height exceeds 30 feet (9145 mm), appliances shall be suspended from the ceiling to a height of 30 feet (9145 mm) maximum above the floor or ground.

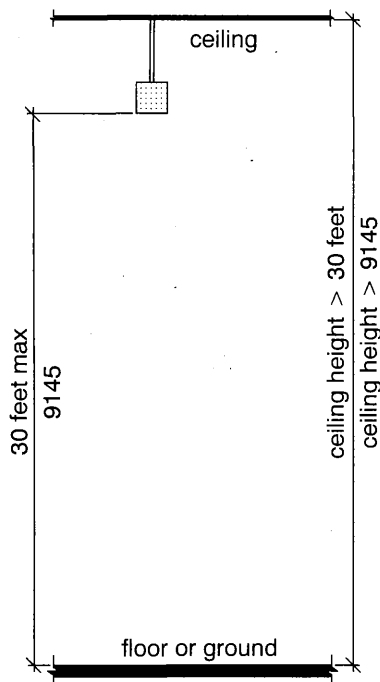

Fig. 702.3.3.2
Location of Ceiling-Mounted Appliances

702.3.4 Spacing and Intensity. Spacing and minimum effective intensity for appliances shall comply with Sections 702.3.4.1 through 702.3.4.3.

EXCEPTIONS:

1. Appliances in corridors shall comply with Section 702.3.5.
2. Appliances in sleeping rooms shall comply with Section 702.3.6.

702.3.4.1 General. The signal provided by the appliance or appliances shall be visible either by direct view or by reflection from all parts of the covered area. Multiple appliances within an area are permitted only where size, shape, building construction, or furnishings prohibit total coverage by a single appliance. Where multiple appliances are provided in a single area to provide total coverage, the appliances shall comply with one of the following:

- (1) A maximum of 2 appliances on opposite walls;
- (2) The appliances shall have synchronized flashes; or
- (3) In rooms 80 feet (24 m) by 80 feet (24 m) or greater in size, more than two appliances such that all appliances in any 135-degree field

of view are spaced a minimum of 55 feet (17 m) from each other.

702.3.4.2 Wall-Mounted Appliances.

Spacing and minimum effective intensity for wall-mounted appliances shall comply with Table 702.3.4.2, provided the appliance is at the midpoint of the longest side of the area served. Where the appliance is not at the midpoint, the minimum effective intensity shall be based on a maximum area of coverage equal to the distance to the opposite side of the area served, or double the distance to the farthest adjacent side of the area served, whichever is greater.

702.3.4.3 Ceiling-Mounted Appliances.

Spacing and minimum effective intensity for ceiling-mounted appliances shall comply with Table 702.3.4.3, provided the appliance is the centerpoint of the area served. Where the appliance is not at the centerpoint, the minimum effective intensity shall be based on a maximum area of coverage equal to two times the distance from the appliance to the farthest side of the area served.

702.3.5 Corridors. Appliances in corridors that are 20 feet (6100 mm) wide maximum shall comply with Section 702.3.5. Appliances in corridors exceeding 20 feet (6100 mm) in width shall comply with Section 702.3.4.

702.3.5.1 Appliance Spacing.

Appliances shall be 15 feet (4570 mm) maximum from each end of the corridor, and shall be 50 feet (15 m) minimum and 100 feet (30 m) maximum apart along the corridor. Interruptions to the concentrated viewing path by doors, elevation changes, or other obstructions shall constitute the end of the corridor for the purpose of this section.

702.3.5.2 Minimum Effective Intensity.

Appliances shall have a minimum effective intensity of 15 candela.

702.3.6 Sleeping Rooms and Suites. Visual alarm appliances required in sleeping rooms and suites shall comply with Sections 702.3.6.1 through 702.3.6.3.

702.3.6.1 Activation.

Where single- or multiple-station smoke detectors are provided in the sleeping room or suite, a visual alarm that is activated upon activation of the smoke detectors shall be provided within the room or suite. Where a building fire alarm system is provided, a visual alarm that is activated upon activation of the

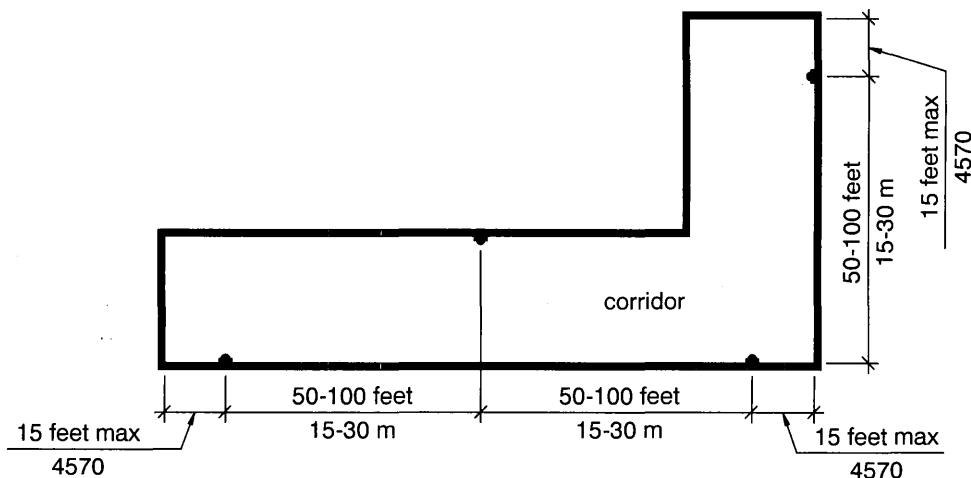

Fig. 702.3.5.1
Appliance Spacing in Corridors

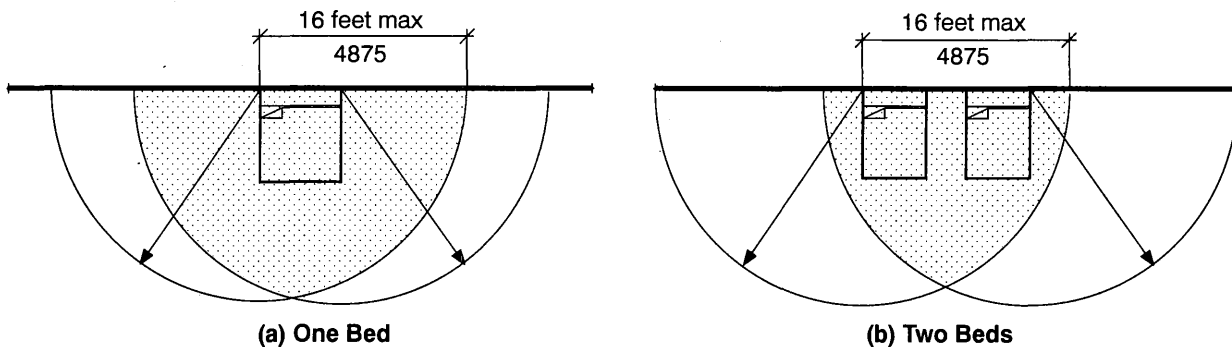

Fig. 702.3.6.2
Appliance Location in Sleeping Rooms

building fire alarm system shall be provided within the room or suite. The signaling line or channel between the activating device of the appliance and the building fire alarm system shall be monitored for integrity by the building fire alarm system. Where the same appliance is used for visual notification of smoke detector and fire alarm system activation, activation of the room or suite smoke detectors shall not activate the building fire alarm system.

702.3.6.2 Location. In sleeping rooms or suites having a linear dimension exceeding 16 feet (4875 mm), the appliance shall be 16 feet (4875 mm) maximum from the head

of the bed location, measured horizontally. Appliances shall be permanently installed. Where a suite contains more than one sleeping room, an appliance shall be provided in each sleeping room.

702.3.6.3 Minimum Effective Intensity and Mounting Height. Wall-mounted appliances 24 inches (610 mm) minimum below the ceiling shall have a minimum effective intensity of 110 candela. Ceiling-mounted appliances and wall-mounted appliances less than 24 inches (610 mm) below the ceiling shall have a minimum effective intensity of 177 candela.

Table 702.3.2(a)—Light Dispersion for Wall-Mounted Visual Alarms

Vertical Dispersion		Horizontal Dispersion	
Degrees from Horizontal	Percent of Rated	Degrees from Vertical	Percent of Rated
0	100	0	100
5-30	90	5-25	90
35	65	30-45	75
40	46	50	55
45	34	55	45
50	27	60	40
55	22	65	35
60	18	70	35
65	16	75	30
70	15	80	30
75	13	85	25
80	12	90	25
85	12	—	—
90	12	—	—

Table 702.3.2(b)—Light Dispersion for Ceiling-Mounted Visual Alarms

Degrees from Vertical	Percent of Rated
0	100
5-25	90
30-45	75
50	55
55	45
60	40
65	35
70	35
75	30
80	30
85	25
90	25

Table 702.3.4.2—Spacing Allocation for Wall-Mounted Visual Alarms

Maximum Area of Coverage	Minimum Required Light Output, Candela (Effective Intensity)		
	One Light per Area	Two Lights per Area	Four Lights per Area
20' x 20'	15	Not Permitted	Not Permitted
30' x 30'	30	15	Not Permitted
40' x 40'	60	30	Not Permitted
50' x 50'	95	60	Not Permitted
60' x 60'	135	95	Not Permitted
70' x 70'	185	95	Not Permitted
80' x 80'	240	135	60
90' x 90'	305	185	95
100' x 100'	375	240	95
110' x 110'	455	240	135
120' x 120'	540	305	135
130' x 130'	635	375	185

Table 702.3.4.3—Spacing Allocation for Ceiling-Mounted Visual Alarms

Maximum Area of Coverage	Minimum Required Light Output, Candela (Effective Intensity)	
	Maximum Ceiling Height	One Light
20' x 20'	10 feet (3050 mm)	15
30' x 30'		30
40' x 40'		60
50' x 50'		95
20' x 20'	20 feet (6100 mm)	30
30' x 30'		45
40' x 40'		80
50' x 50'		115
20' x 20'	30 feet (9145 mm)	55
30' x 30'		75
40' x 40'		115
50' x 50'		150

703 Signs

703.1 General. Accessible signs shall comply with Section 703.

703.2 Characters that are both Tactile and Visual. Characters required to be tactile shall comply with Sections 703.2.1 through 703.2.8.

EXCEPTION: Tactile characters complying with Section 703.3, where separate visual characters complying with Section 703.4 provide the same information.

703.2.1 Braille. Tactile characters shall be duplicated in Braille complying with Section 703.5.

703.2.2 Finish and Contrast. Characters and their background shall have a non-glare finish. Characters shall contrast with their background, with either light characters on a dark background, or dark characters on a light background.

703.2.3 Tactile Character Depth. Tactile characters shall be raised $\frac{1}{32}$ inch (0.8 mm) minimum above their background. Raised borders and elements that are not required shall be $\frac{3}{8}$ inch (9.5 mm) minimum from tactile characters.

703.2.4 Character Forms. Fonts shall have characters complying with Sections 703.2.4.1 through 703.2.4.5.

703.2.4.1 Case. Characters shall be uppercase.

703.2.4.2 Style. Characters shall be sans serif. Characters shall not be italic, oblique, script, highly decorative, or of other unusual forms.

703.2.4.3 Width. Character width shall be 55 percent minimum and 110 percent maximum of the height of the character, with the width based on the uppercase letter "O" and the height based on the uppercase letter "I."

703.2.4.4 Height. Character height, measured vertically from the baseline of the character, shall be $\frac{5}{8}$ inch (16 mm) minimum, and 2 inches (51 mm) maximum, based on the uppercase letter "I."

703.2.4.5 Stroke Thickness. Characters with rectangular cross sections shall have a stroke thickness which is 10 percent minimum, and 15 percent maximum, of the height of the character, based on the uppercase letter "I". Characters with other cross

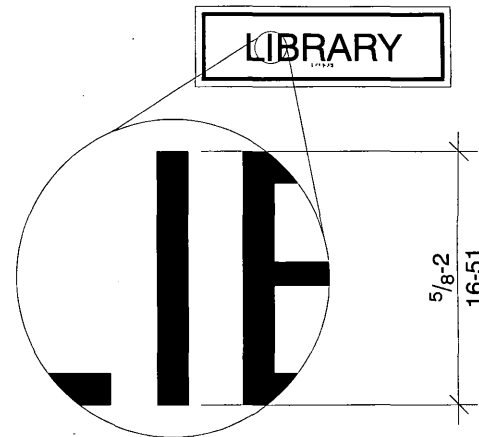

Fig. 703.2.4.4
Character Height

sections shall have a stroke thickness at the base of the cross sections which is 10 percent minimum, and 30 percent maximum, of the height of the character, and a stroke thickness at the top of the cross sections which is 15 percent maximum of the height of the character, based on the uppercase letter "I".

703.2.5 Character Spacing. Spacing shall be measured between the two closest points of adjacent characters within a message, excluding word spaces. Where characters have rectangular cross sections, spacing between individual characters shall be $\frac{1}{8}$ inch (3.2 mm) minimum and $\frac{3}{8}$ inch (9.5 mm) maximum. Where characters have other cross sections, spacing between individual characters shall be $\frac{1}{16}$ inch (1.6 mm) minimum and $\frac{3}{8}$ inch (9.5 mm) maximum at the base of the cross sections, and $\frac{1}{8}$ inch (3.2 mm) minimum and $\frac{3}{8}$ inch (9.5 mm) maximum at the top of the cross sections.

703.2.6 Line Spacing. Spacing between the baselines of separate lines of characters shall be 135 percent minimum to 170 percent maximum of the character height.

703.2.7 Mounting Height. Characters shall be 48 inches (1220 mm) minimum and 60 inches (1525 mm) maximum above the adjacent floor or ground surface, measured from the baseline of the characters.

EXCEPTION: Elevator car controls.

703.2.8 Mounting Location. Where a sign containing tactile characters is provided at a door, the sign shall be alongside the door on the latch side. Where a tactile sign is provided at double doors, the sign shall be to the right of the

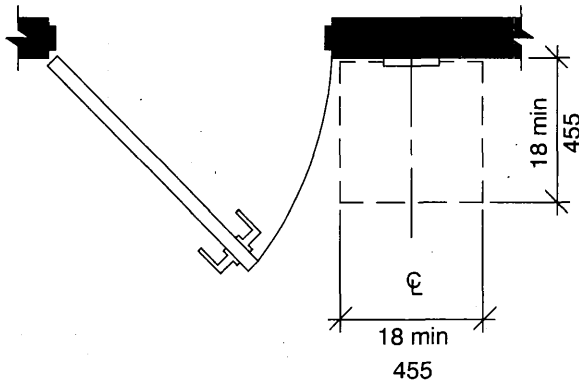

Fig. 703.2.8
Mounting Location at Doors

right-hand door. Where there is no wall space on the latch side of a single door, or to the right side of double doors, signs shall be on the nearest adjacent wall. Signs containing tactile characters shall have an 18 inch (455 mm) minimum by 18 inch (455 mm) minimum space on the floor or ground, centered on the sign, beyond the arc of any door swing between the closed position and 45 degree open position.

EXCEPTION: Door-mounted signs shall be permitted on the push side of doors with closers and without hold-open devices.

703.3 Tactile Characters. Where tactile characters are required, and separate tactile and visual characters with the same information are provided, tactile characters shall comply with Sections 703.3.1 through 703.3.7 and visual characters shall comply with Section 703.4.

703.3.1 Braille. Tactile characters shall be duplicated in Braille complying with Section 703.5.

703.3.2 Tactile Character Depth. Tactile characters shall be raised $\frac{1}{32}$ inch (0.8 mm) minimum above their background. Raised borders and elements that are not required shall be $\frac{3}{8}$ inch (9.5 mm) minimum from tactile characters.

703.3.3 Character Forms. Fonts shall have characters complying with Sections 703.3.3.1 through 703.3.3.5.

703.3.3.1 Case. Characters shall be uppercase.

703.3.3.2 Style. Characters shall be sans serif. Characters shall not be italic, oblique, script, highly decorative, or of other unusual forms.

703.3.3.3 Width. Character width shall be 55 percent minimum and 110 percent maximum the height of the character, with the width based on the uppercase letter "O," and the height based on the uppercase letter "I."

703.3.3.4 Height. Character height, measured vertically from the baseline of the character, shall be $\frac{1}{2}$ inch (13 mm) minimum, and $\frac{3}{4}$ inch (19 mm) maximum, based on the height of the uppercase letter "I."

703.3.3.5 Stroke Thickness. Characters shall have a stroke thickness which is 15 percent maximum of the height of the character, based on the uppercase letter "I."

703.3.4 Character Spacing. Spacing shall be measured between the two closest points of adjacent characters within a message, excluding word spaces. Spacing between individual characters shall be $\frac{1}{8}$ inch (3.2 mm) minimum to $\frac{1}{4}$ inch (6.4 mm) maximum.

703.3.5 Line Spacing. Spacing between the baseline of separate lines of characters within a message shall be 135 percent minimum and 170 percent maximum of the character height.

703.3.6 Mounting Height. Characters shall be 48 inches (1220 mm) minimum and 60 inches (1525 mm) maximum above the adjacent floor or ground surface, measured from the baseline of the characters.

EXCEPTION: Elevator car controls.

703.3.7 Mounting Location. Where a tactile sign is provided at a door, the sign shall be alongside the door on the latch side. Where a tactile sign is provided at double doors, the sign shall be to the right of the right-hand door. Where there is no wall space on the latch side of a single door, or to the right side of double doors, signs shall be on the nearest adjacent wall. Signs containing tactile characters shall have an 18 inch (455 mm) minimum by 18 inch (455 mm) minimum space on the floor or ground, centered on the sign, beyond the arc of any door swing between the closed position and 45 degree open position.

EXCEPTION: Door-mounted signs shall be permitted on the push side of doors with closers and without hold-open devices.

703.4 Visual Characters. Accessible visual characters shall comply with Sections 703.4.1 through 703.4.5.

703.4.1 Finish and Contrast. Characters and their background shall have a non-glare finish. Characters shall contrast with their background, with either light characters on a dark background, or dark characters on a light background.

703.4.2 Character Forms. Fonts shall have characters complying with Sections 703.4.2.1 through 703.4.2.5.

703.4.2.1 Case. Characters shall be uppercase, lowercase, or a combination of both.

703.4.2.2 Style. Characters shall be conventional in form. Characters shall not be italic, oblique, script, highly decorative, or of other unusual forms.

703.4.2.3 Width. Character width shall be 55 percent minimum and 110 percent maximum the height of the character, with the width based on the uppercase letter "O," and the height based on the uppercase "I."

703.4.2.4 Height. Minimum character height, measured from the baseline of the character, shall comply with Table 703.4.2.4, based on the height of the characters above the floor or ground of the viewing location and the minimum viewing distance. Character height shall be based on the uppercase letter "I." Minimum viewing

distance shall be measured as the horizontal distance where an obstruction prevents further approach toward the sign.

703.4.2.5 Stroke Thickness. Characters shall have a stroke thickness which is 10 percent minimum, and 30 percent maximum, the height of the character, based on the uppercase letter "I."

703.4.3 Character Spacing. Spacing shall be the two closest points of adjacent characters within a message, excluding word spaces. Spacing between individual characters shall be 10 percent minimum and 35 percent maximum of character height.

703.4.4 Line Spacing. Spacing between the baselines of separate lines of characters within a message shall be 135 percent minimum to 170 percent maximum of character height.

703.4.5 Mounting Height. Visual characters shall be 40 inches (1015 mm) minimum above the floor or ground of the viewing position. Mounting heights shall comply with Table 703.4.2.4, based on the size of the characters on the sign.

703.5 Braille. Tactile characters shall be accompanied by Grade II Braille complying with Sections 703.5.1 through 703.5.4 and Table 703.5. Braille dots shall have a domed or rounded shape.

Table 703.4.2.4—Minimum Character Heights for Visual Signs

Height above Floor or Ground to Top of Character	Minimum Viewing Distance	Minimum Character Height	Notes
40 inches - ≤70 inches (1015 mm - 1780 mm)	≤ 6 feet (1830 mm)	5/8 inch (16 mm)	Except elevators
40 inches - ≤70 inches (1015 mm - 1780 mm)	> 6 feet (1830 mm)	5/8 inch (16 mm), plus 1/8 inch per foot (3.2 mm per 305 mm) of viewing distance beyond 6 feet (1830 mm)	Except elevators
>70 inches - ≤120 inches (1780 mm - 3050 mm)	≤ 15 feet (4570 mm)	2 inches (51 mm)	
>70 inches - ≤120 inches (1780 mm - 3050 mm)	> 15 feet (4570 mm)	2 inches (51 mm), plus 1/8 inch per foot (3.2 mm per 305 mm) of viewing distance beyond 15 feet (4570 mm)	
> 120 inches (3050 mm)	≤ 21 feet (6400 mm)	3 inches (76 mm)	
> 120 inches (3050 mm)	> 21 feet (6400 mm)	3 inches (76 mm), plus 1/8 inch per foot (3.2 mm per 305 mm) of viewing distance beyond 21 feet (6400 mm)	

Table 703.5—Measurement Range for Standard Sign Braille

Measurement Range for:	Minimum	Maximum
Dot base diameter	0.059 inch (1.5 mm)	0.063 inch (1.6 mm)
Distance between two dots in same cell, center to center	0.090 inch (2.3 mm)	0.100 inch (2.5 mm)
Distance between corresponding dots in adjacent cells, center to center	0.241 inch (6.1 mm)	0.300 inch (7.6 mm)
Dot Height	0.025 inch (0.6 mm)	0.037 inch (0.9 mm)
Distance between corresponding dots from one cell to the cell directly below, center to center	0.395 inch (10.0 mm)	0.400 inch (10.2 mm)

703.5.1 Location. Braille shall be below the corresponding text. If text is multilined, Braille shall be placed below entire text. Braille shall be separated $\frac{3}{8}$ inch (9.5 mm) minimum from any other tactile characters.

EXCEPTION: Braille provided on elevator car controls shall be separated $\frac{3}{16}$ inch (4.8 mm) minimum either directly below or adjacent to the corresponding raised characters or symbols.

703.5.2 Raised Elements and Borders. Raised borders and elements that are not required shall be $\frac{3}{8}$ inch (9.5 mm) minimum from tactile characters.

703.5.3 Height. Braille shall be 40 inches (1015 mm) minimum, and 60 inches (1525 mm) maximum, above the floor or ground, measured from the baseline of the Braille cells.

EXCEPTION: Elevator car controls.

703.5.4 Braille Standard. Braille shall comply with literary Braille.

EXCEPTION: The indication of an uppercase letter or letters shall only be used before the first word of sentences, proper nouns and names, individual letters of the alphabet, initials, or acronyms.

703.6 Pictograms. Pictograms shall comply with Sections 703.6.1 through 703.6.3.

703.6.1 Pictogram Field. Pictograms shall have a field with a height of 6 inches (150 mm) minimum. Characters or Braille shall not be in the pictogram field.

703.6.2 Finish and Contrast. Pictograms and their fields shall have a non-glare finish. Pictograms shall contrast with their fields, with either a light pictogram on a dark field or a dark pictogram on a light field.

703.6.3 Text Descriptors. Where text descriptors for pictograms are required, they shall be directly below or adjacent to the pictogram and shall comply with Section 703.2.

703.7 Symbols of Accessibility. Symbols of accessibility shall comply with Sections 703.7.1 through 703.7.2.

703.7.1 Finish and Contrast. Symbols of accessibility and their backgrounds shall have a non-glare finish. Symbols of accessibility shall contrast with their backgrounds, with either a light symbol on a dark background or a dark symbol on a light background.

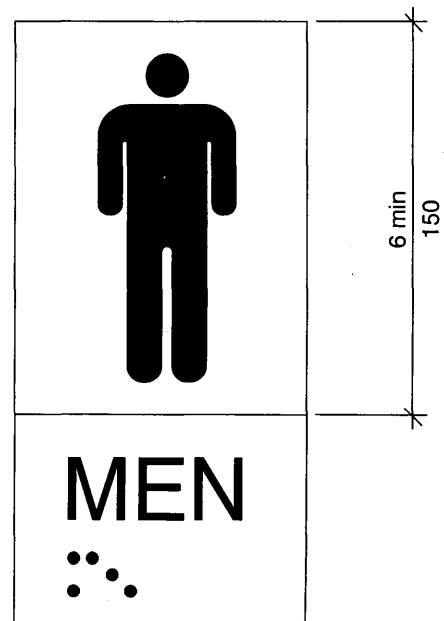

Fig. 703.6.1 Pictogram Field

703.7.2 Symbols

703.7.2.1 International Symbol of Accessibility. Where the International Symbol of Accessibility is required, it shall be proportioned complying with Figure 703.7.2.1.

703.7.2.2 International Symbol of TTY. Where the International Symbol of TTY is required, it shall comply with Figure 703.7.2.2.

703.7.2.3 Volume-Controlled Telephones. Where telephones with volume controls are required to be identified, the identification symbol shall be a telephone handset with radiating sound waves, such as shown in Figure 703.7.2.3.

703.7.2.4 Assistive Listening Systems. Where assistive listening systems are re-

quired to be identified by the International Symbol of Access for Hearing Loss, it shall comply with Figure 703.7.2.4.

704 Telephones

704.1 General. Accessible public telephones shall comply with Section 704.

704.2 Wheelchair Accessible Telephones. Wheelchair accessible public telephones shall comply with Sections 704.2.1 through 704.2.5.

704.2.1 Clear Floor or Ground Space. A clear floor or ground space complying with Section 305 shall be provided. The clear floor or ground space shall not be restricted by bases, enclosures, or fixed seats.

704.2.1.1 Parallel Approach. Where a parallel approach is provided, the distance



Fig. 703.7.2.1
International Symbol of Accessibility



Fig. 703.7.2.2
International TTY Symbol



Fig. 703.7.2.3
Volume-Controlled Telephone



Fig. 703.7.2.4
International Symbol of Access for Hearing Loss

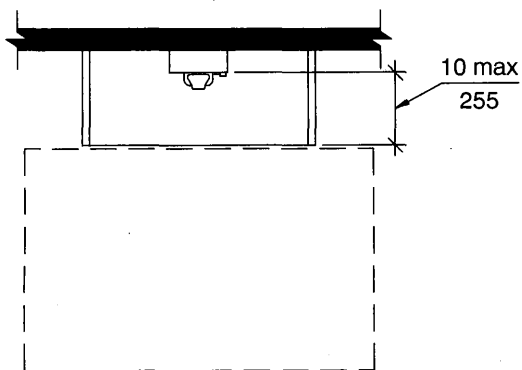

(a) Parallel Approach

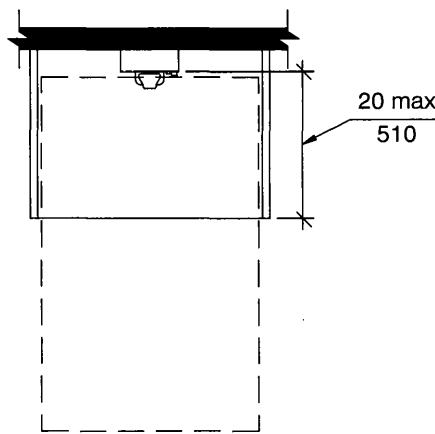

(b) Forward Approach

Fig. 704.2.1
Clear Floor or Ground Space for Telephones

from the edge of the telephone enclosure to the face of the telephone unit shall be 10 inches (255 mm) maximum.

704.2.1.2 Forward Approach. Where a forward approach is provided, the distance from the front edge of a counter within the enclosure to the face of the telephone unit shall be 20 inches (510 mm) maximum.

704.2.2 Operable Parts. The highest operable part of the telephone shall be within the reach ranges specified in Section 308. Telephones shall have push button controls where service for such equipment is available.

704.2.3 Telephone Directories. Where provided, telephone directories shall comply with Section 309.

704.2.4 Cord Length. Wheelchair accessible telephones shall be equipped with a handset cord length of 29 inches (735 mm) minimum.

704.2.5 Hearing-Aid Compatibility. Telephones shall be hearing-aid compatible.

704.3 Volume-Control Telephones. Telephones with volume control shall be equipped with a receive volume control with a range that provides 12 dB of gain minimum and 20 dB of gain maximum. An automatic reset shall be provided.

704.4 TTY. Where used with a pay telephone, text telephones shall be permanently affixed within, or adjacent to, the telephone enclosure. If an acoustic coupler is used, the telephone cord shall be sufficiently long to allow connection of the TTY and the telephone receiver.

704.5 TTY Shelf. Where pay telephones designed to accommodate a portable TTY are provided, they shall be equipped with a shelf and an electrical outlet within or adjacent to the telephone enclosure. The telephone handset shall be capable of being placed flush on the surface of the shelf. The shelf shall be capable of accommodating a TTY and shall have a 6 inches (150 mm) high minimum vertical clearance above the area where the TTY is placed.

704.6 Protruding Objects. Telephones, enclosures, and related equipment shall comply with Section 307.

705 Detectable Warnings

705.1 General. Detectable warnings shall comply with Sections 705.2 and 705.3.

705.2 Standardization. Detectable warnings shall be standard within a building, facility, site, or complex of buildings.

705.3 Platform Edge Detectable Warnings. A platform edge detectable warning shall comply with Section 705.3.1, 705.3.2, or 705.3.3.

705.3.1 Truncated Domes. A 24 inch (610 mm) wide tactile pattern of raised truncated domes complying with Sections 705.3.1.1 through 705.3.1.3 shall be provided on the walking surface at the platform edge.

705.3.1.1 Dome Size. Domes shall have a diameter of 0.9 inch (23 mm), a height of 0.2 inch (5 mm), and a center-to-center spacing of 2.35 inches (60 mm).

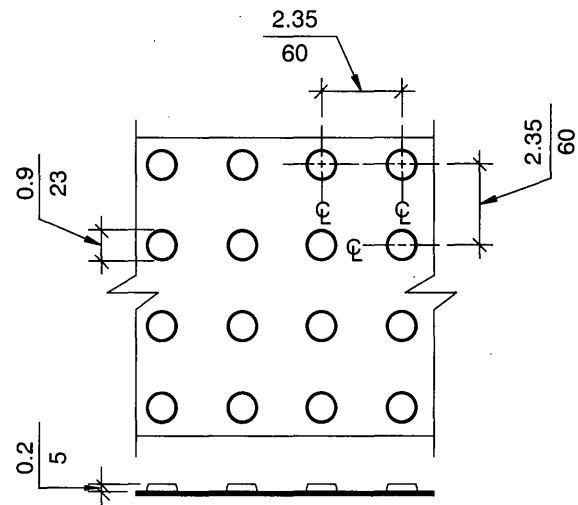

Fig. 705.3.1.1
Truncated Dome Size

705.3.1.2 Contrast. The truncated dome surface shall contrast visually with adjoining surfaces, either light-on-dark or dark-on-light. The material used to provide contrast shall be an integral part of the truncated dome surface.

705.3.1.3 Interior Locations. Detectable warnings in interior locations shall differ from adjoining walking surfaces in resiliency or sound-on-cane contact.

705.3.2 Equivalent Tactile Surface. A 24 inch (610 mm) wide tactile surface of equivalent detectability underfoot shall be provided and shall comply with Section 705.3.1.2.

705.3.3 Equivalent Detectability. Detectability by other construction, technology, or means shall be provided that will ensure equivalent or

superior, reliable communication of the impending change to pedestrians who are blind or visually impaired. The information to be communicated must include 24 inches (610 mm) of advance warning of the platform edge and the precise orientation of the platform edge in relation to the pedestrian.

706 Assistive Listening Systems

706.1 General. Accessible assistive listening systems in assembly areas shall comply with Section 706.

706.2 Placement. Individual fixed seats, served by an assistive listening system, shall have complete view of the stage, playing area, or cinema screen.

706.3 Types of Systems. Induction loops, infrared systems, FM and AM radio frequency systems, hard-wired earphones, and other equivalent devices shall be permitted as acceptable listening systems.

707 Automatic Teller Machines (ATMs) and Fare Machines

707.1 General. Automatic teller machines and fare machines that are required to be accessible shall comply with Section 707.

707.2 Clear Floor or Ground Space. A clear floor or ground space complying with Section 305 shall be provided.

EXCEPTION: Clear floor or ground space is not required at drive-up only machines.

707.3 Operable Parts. Operable parts shall comply with Section 309. Each operable part shall be able to be differentiated by sound or touch, without activation.

EXCEPTION: Drive-up only machines shall not be required to comply with Section 309.2 or 309.3.

707.4 Input. Input devices shall comply with Sections 707.4.1 through 707.4.5.

707.4.1 Privacy. The opportunity for the same degree of privacy of input shall be available to all individuals utilizing the equipment.

707.4.2 Key Surfaces. All keys used to operate a machine shall be tactually discernible. Key surfaces shall be offset from the surrounding surface by $1/25$ inch (1 mm) minimum. The outer

edge of key surfaces shall have a radius of $1/50$ inch (0.5 mm) maximum.

EXCEPTION: The touch areas of video display screens.

707.4.3 Separation Between Keys. Any key surface shall be separated from other key surfaces by $1/8$ inch (3.2 mm) minimum. Function keys shall be separated from the keypad equal to a distance that is not less than three times greater than the actual distance between the numeric keys.

707.4.4 Numeric Keys. Where provided, numeric keys shall comply with Sections 707.4.4.1 and 707.4.4.2.

707.4.4.1 Arrangement. Numeric keys shall be arranged in a 12-key telephone keypad layout with the number one key in the upper left hand corner.

707.4.4.2 Marking. The number five key shall have a single raised dot.

707.4.5 Function Keys. Where provided, function keys shall comply with Sections 707.4.5.1 through 707.4.5.3.

707.4.5.1 Arrangement. Function keys shall be in the order of enter, clear, cancel, add value, and decrease value horizontally from left to right or vertically from top to bottom. Where provided, add value and decrease value shall be grouped with other function keys.

707.4.5.2 Marking. Function keys shall be marked with tactile characters as follows:

- Enter or proceed key: raised circle;
- Clear or correct key: raised vertical line or bar;
- Cancel key: raised letter "x";
- Add value key: raised plus sign;
- Decrease value key: raised minus sign.

707.4.5.3 Color Coding. Where function keys are color coded, they shall be colored as follows:

- Enter or proceed key: green;
- Clear or correct key: black;
- Cancel key: red;
- Add value key: blue;
- Decrease value key: yellow.

707.5 Output. Output devices shall comply with Sections 707.5.1 through 707.5.6.

707.5.1 Privacy. The opportunity for the same degree of privacy of output shall be available to all individuals utilizing the equipment.

707.5.2 Operating Instructions. Machines shall provide visual and audible instruction for operation. Visual and audible instruction shall include all information required by Sections 707.5.2.1 through 707.5.2.5.

707.5.2.1 Initiation. Instruction shall be initiated by the user of the machine.

707.5.2.2 Expedited Process. After initiation, instructions shall be available to the experienced user to expedite the transaction.

707.5.2.3 Orientation. Orientation and assistance for unfamiliar users to the physical features of the machine, operational options, and details for each function shall be provided.

707.5.2.4 Transaction Prompts. All transaction prompts within each operation shall be provided.

707.5.2.5 Input Verification. Verification of all user inputs shall be provided.

707.5.3 Audible Instruction. Audible instruction shall be provided through a standard audio mini jack, a telephone handset, a wireless

transmission system, or another mechanism that is readily available to all customers.

707.5.4 Video Display Screen. The video display screen shall comply with Sections 707.5.4.1 and 707.5.4.2.

707.5.4.1 Visibility. The video display screen shall be visible from a point 40 inches (1015 mm) above the center of the clear floor or ground space in front of the machine.

EXCEPTION: This requirement shall not apply to drive-up only machines.

707.5.4.2 Characters. Characters displayed on the screen shall be in a sans serif font. Characters shall be $\frac{3}{16}$ inch (4.8 mm) high minimum, based on the uppercase letter "I." Characters shall contrast with the background with either light characters on a dark background, or dark characters on a light background.

707.5.5 Dispensing of Bills. Machines that dispense paper currency shall dispense the currency so that bills are dispensed in descending order with the lowest denomination on top.

707.5.6 Receipts and Verification. Where a receipt is available and is requested, the following options shall be provided: a printed receipt, audible presentation of the transaction information provided on the receipt, or both.

Chapter 8. Special Rooms and Spaces

801 General

801.1 Scope. Special rooms and spaces required to be accessible by the scoping provisions adopted by the administrative authority shall comply with the applicable provisions of this chapter.

802 Auditorium and Assembly Areas

802.1 General. Wheelchair spaces in auditorium and assembly areas with fixed seating shall comply with Section 802.

802.2 Surfaces. The floor or ground surface of wheelchair spaces shall have a slope not steeper than 1:48 and shall comply with Section 302.

802.3 Width. A single wheelchair space shall be 36 inches (915 mm) wide minimum. Where multiple adjacent wheelchair spaces are provided, each wheelchair space shall be 33 inches (840 mm) wide minimum.

802.4 Depth. Where a wheelchair space can be entered from the front or rear, the wheelchair space shall be 48 inches (1220 mm) deep minimum. Where a wheelchair space can only be entered from the side, the wheelchair space shall be 60 inches (1525 mm) deep minimum.

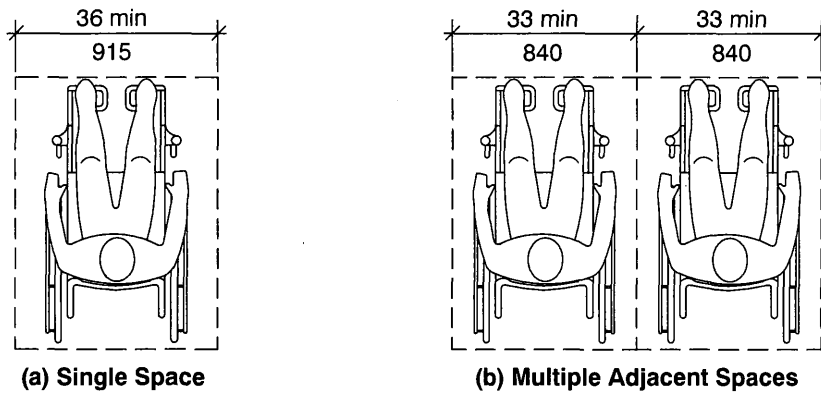

Fig. 802.3
Width of a Wheelchair Space in Auditorium and Assembly Areas

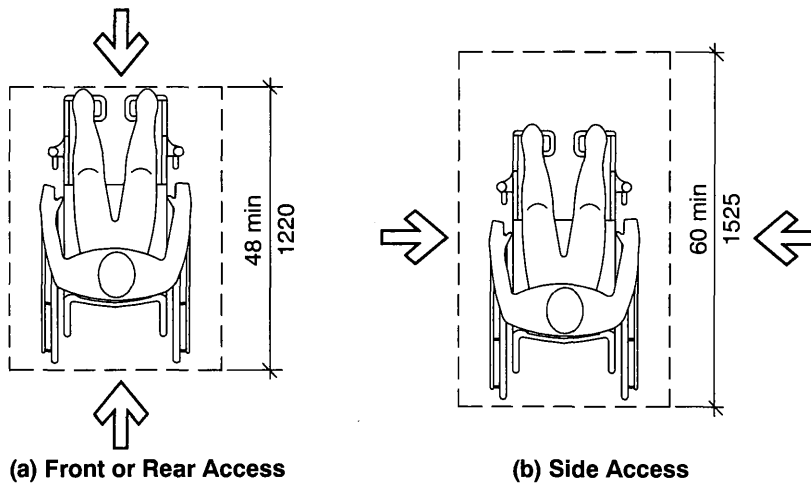

Fig. 802.4
Depth of a Wheelchair Space in Auditorium and Assembly Areas

802.5 Approach. One side of the wheelchair space shall adjoin an accessible route or adjoin another wheelchair space. Access to any wheelchair space shall not be through more than one adjoining wheelchair space.

802.6 Integral Part of Seating. Wheelchair locations shall be an integral part of any fixed seating.

802.7 Companion Seat. At least one seat for a companion shall be provided beside each wheelchair space.

802.8 Lines of Sight. Wheelchair spaces shall provide lines of sight comparable to those of all viewing areas.

803 Dressing, Fitting, and Locker Rooms

803.1 General. Accessible dressing, fitting, and locker rooms shall comply with Section 803.

803.2 Wheelchair Turning Space. A wheelchair turning space complying with Section 304 shall be provided within the room.

803.3 Doors. Doors shall not swing into any part of the turning space.

803.4 Benches. A bench complying with Section 903 shall be provided within the room.

803.5 Coat Hooks and Shelves. Accessible coat hooks provided within dressing and fitting rooms shall accommodate a forward reach or side reach complying with Section 308. Where provided, a fold-down shelf shall be 40 inches (1015 mm) minimum and 48 inches (1220 mm) maximum above the floor or ground.

804 Kitchens

804.1 General. Accessible kitchens shall comply with Section 804.

804.2 Clearance. Clearance complying with Sections 804.2.1 and 804.2.2 shall be provided.

804.2.1 Galley Areas. Clearance between all opposing base cabinets, counter tops, appliances, or walls within kitchen work areas shall be 40 inches (1015 mm) minimum.

804.2.2 U-Shaped Areas. In kitchens with counters, appliances, or cabinets on three contiguous sides, clearance between all opposing base cabinets, countertops, appliances, or walls within kitchen work areas shall be 60 inches (1525 mm) minimum.

804.3 Wheelchair Turning Space. A wheelchair turning space complying with Section 304 shall be provided within the room. The wheelchair turning space shall be adjacent to or overlap clear floor or ground areas required by Section 804.

804.4 Work Surface. The work surface shall comply with Section 902.

804.5 Sink. The sink and surrounding counter shall comply with Section 606.

804.6 Kitchen Storage. Kitchen storage shall comply with Section 905.

804.7 Appliances. Where provided, kitchen appliances shall comply with Sections 804.7.1 through 804.7.6.

804.7.1 Clear Floor or Ground Space. A clear floor or ground space complying with Section 305 shall be provided at each kitchen appliance. Clear floor or ground spaces are permitted to overlap.

804.7.2 Operating Controls. All appliance controls shall comply with Section 309.

804.7.3 Dishwasher. Clear floor or ground space shall be positioned adjacent to the dishwasher door. The dishwasher door in the open position shall not obstruct the clear floor or ground space for the dishwasher or the sink.

804.7.4 Range or Cooktop. Where a forward approach clear floor or ground space is provided, the clear floor or ground space shall provide knee and toe clearance complying with Section 306. Where knee and toe space is provided, the underside of the range or cooktop shall be insulated or otherwise configured to prevent burns, abrasions, or electrical shock. The location of controls shall not require reaching across burners.

804.7.5 Oven. For side-opening ovens, the door latch side shall be next to a countertop. Ovens shall have controls on front panels, on either side of the door.

804.7.6 Refrigerator/Freezer. Combination refrigerators and freezers shall have at least 50 percent of the freezer space 54 inches (1370 mm) maximum above the floor or ground. The clear floor or ground space shall be positioned for a parallel approach to the space dedicated to a refrigerator/freezer with the centerline of the clear floor or ground space offset 24 inches (610 mm) maximum from the centerline of the dedicated space.

Chapter 9. Built-In Furnishings and Equipment

901 General

901.1 Scope. Built-in furnishings and equipment required to be accessible by the scoping provisions adopted by the administrative authority shall comply with the applicable provisions of this chapter.

902 Seating at Tables, Counters, and Work Surfaces

902.1 General. Accessible seating at fixed tables, counters and work surfaces shall comply with Section 902.

902.2 Clear Floor or Ground Space. Clear floor or ground space complying with Section 305 shall be provided. Knee and toe clearance complying with Section 306 shall be provided.

902.3 Height. The tops of tables, counters, and work surfaces shall be 28 inches (710 mm) minimum and 34 inches (865 mm) maximum from the floor or ground.

902.4. Food and Drink Counters. Accessible food and drink counters shall be 60 inches (1525 mm) long minimum.

903 Benches

903.1 General. Benches required to be accessible shall comply with Section 903.

903.2 Clear Floor or Ground Space. Clear floor or ground space complying with Section 305 shall be provided and shall be positioned for parallel approach to an end of the bench seat.

903.3 Size. Bench seats shall be 20 inches (510 mm) minimum and 24 inches (610 mm) wide maximum by 42 inches (1065 mm) minimum long fixed to a wall along the longer dimension.

903.4 Height. The bench shall be 17 inches (430 mm) minimum and 19 inches (485 mm) maximum above the floor or ground.

903.5 Structural Strength. Allowable stresses in bending, shear, and tension shall not be exceeded for materials used where a vertical or horizontal

force of 250 pounds (1112 N) is applied at any point on the seat, fastener mounting device, or supporting structure.

903.6 Wet Locations. Where provided in wet locations the surface of the bench shall be slip resistant and water shall not accumulate on the surface.

904 Checkout and Service Counters

904.1 General. Accessible checkout and service counters shall comply with the applicable provisions of Section 904.

904.2 Checkout Counters. Checkout counter surfaces shall be 38 inches (965 mm) maximum above the floor or ground. The top of the counter edge protection shall be 2 inches (51 mm) maximum above the counter surface.

904.3 Service Counters. Counters for sales or distribution of goods and services to the public shall have a portion of the counter 36 inches (915 mm) long minimum by 36 inches (915 mm) high maximum above the floor or ground.

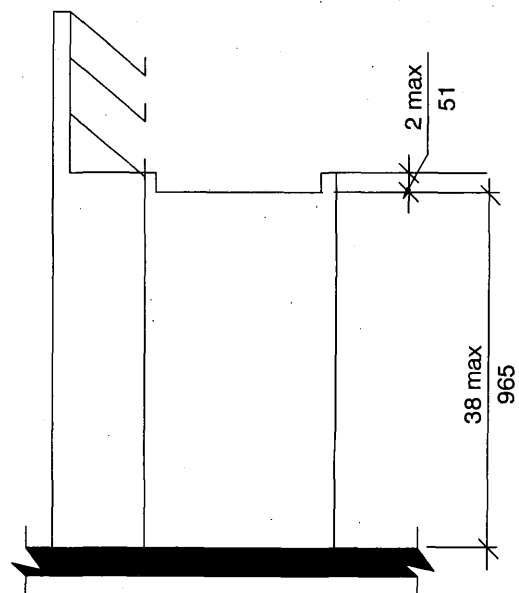

Fig. 904.2
Height of Checkout Counters

904.4 Tray Slides. The tops of accessible portions of tray slides shall be 28 inches (710 mm) minimum and 34 inches (865 mm) maximum above the floor or ground.

905 Storage Facilities

905.1 General. Accessible storage facilities shall comply with Section 905.

905.2 Clear Floor or Ground Space. A clear floor or ground space complying with Section 305 shall be provided.

905.3 Height. Accessible storage areas shall comply with at least one of the reach ranges specified in Section 308.

905.4 Operable Parts. Operable parts of storage facilities shall comply with Section 309.4.

Chapter 10. Dwelling Units

1001 General

1001.1 Scoping. Dwelling units required to be accessible by the scoping provisions adopted by the administrative authority shall comply with the applicable provisions of this chapter.

1002 Type A Dwelling Units

1002.1 General. Type A dwelling units shall comply with Section 1002.

1002.2 Primary Entrance. The accessible primary entrance shall be on an accessible route from public and common areas. The primary entrance shall not be to a bedroom.

1002.3 Accessible Route. Accessible routes within Type A dwelling units shall comply with Sections 1002.3.1 through 1002.3.3.

EXCEPTIONS:

1. Exterior spaces less than 30 inches (760 mm) in depth or width shall comply with Sections 1002.3.1, 1002.3.3, 302, and 303.
2. Attics and unfinished basements.

1002.3.1 Location. At least one accessible route shall connect all spaces and elements which are a part of the dwelling unit. Where only one accessible route is provided, it shall not pass through restrooms, closets, or similar spaces.

1002.3.2 Wheelchair Turning Space. All spaces shall provide a wheelchair turning space complying with Section 304.

1002.3.3 Components. Accessible routes shall consist of one or more of the following elements: floor or ground surfaces with a slope not steeper than 1:20, ramps, elevators, and wheelchair (platform) lifts.

1002.4 Walking Surfaces. Walking surfaces that are part of an accessible route shall comply with Section 403.

1002.5 Doors and Doorways. The primary entrance door to the dwelling unit, and all other doorways intended for user passage, shall comply with Section 404.

EXCEPTION: Thresholds at exterior sliding doors shall be permitted to be $\frac{3}{4}$ inch (19 mm) high maximum provided they are beveled with a slope not greater than 1:2.

1002.6 Ramps. Ramps shall comply with Section 405.

1002.7 Private Residence Elevators. Elevators shall comply with Sections 1002.7.1 through 1002.7.8.

EXCEPTION: Elevators complying with Section 407.

1002.7.1 Automatic Operation. Elevator operation shall be automatic. Each car shall automatically stop at a floor landing within a tolerance of $\frac{1}{2}$ inch (13 mm) under rated loading to zero loading conditions.

1002.7.2 Call Buttons. Call buttons at elevator landings shall comply with Section 309.3. Call buttons shall be $\frac{3}{4}$ inch (19 mm) minimum in their smallest dimension.

1002.7.3 Doors and Gates. Elevator car and hoistway doors and gates shall comply with Section 404, except that the maneuvering clearances required by Section 404.2.4.1 for approaches to the push side of swinging doors shall not apply. Elevator car doors and gates shall be power operated. For elevators with a car that has more than one opening, the hoistway doors and gates shall be permitted to be of the manual-open, self-close type. Elevators with a single opening car shall have low-energy power-operated hoistway doors and gates. Power operated doors and gates shall comply with ANSI/BHMA A156.19 and shall remain open for 20 seconds minimum when activated.

1002.7.4 Inside Dimensions of Elevator Cars. Elevator cars shall provide a clear floor space of 30 inches (760 mm) minimum by 48 inches (1220 mm) minimum. Car gates or doors shall be positioned at the narrow end of the clear floor space. The clearance between the car platform sill and the edge of any hoistway landing shall be $1\frac{1}{4}$ inches (32 mm) maximum.

1002.7.5 Floor Surfaces. Floor surfaces in elevator cars shall comply with Sections 302 and 303.

1002.7.6 Illumination Levels. The level of illumination at the car controls, platform, and car threshold and landing sill shall be 5 footcandles (54 lux) minimum.

1002.7.7 Car Controls. Elevator car controls shall comply with Sections 1002.7.7.1 through 1002.7.7.3.

1002.7.7.1 Buttons. Control buttons shall be $\frac{3}{4}$ inch (19 mm) minimum in their smallest dimension. Control buttons shall be raised or flush.

1002.7.7.2 Height. Buttons with floor designations shall comply with Section 309.3.

1002.7.7.3 Location. Controls shall be on a side wall, 12 inches (305 mm) minimum from any adjacent wall.

1002.7.8 Emergency Communications. A telephone and emergency signal device shall be provided in the car and shall comply with ASME/ANSI A17.1, Rule 509. The telephone and emergency signaling device shall comply with Section 309.3. If the device is in a closed compartment, the compartment door hardware shall comply with Section 309. The telephone cord shall be 29 inches (735 mm) long minimum.

1002.8 Wheelchair Lifts. Wheelchair (platform) lifts shall comply with ASME/ANSI A17.1 and with Sections 302, 305, and 309.

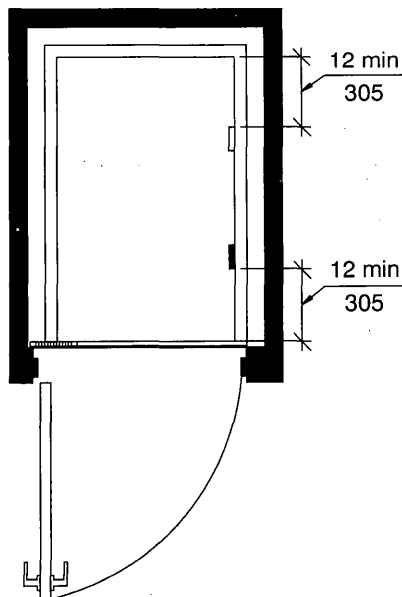

Fig. 1002.7.7.3
Location of Controls in Private
Residence Elevators

1002.9 Operable Parts. Lighting controls, electrical switches and receptacles, environmental controls, appliance controls, operating hardware for operable windows, plumbing fixture controls, and user controls for security or intercom systems shall comply with Section 309.

EXCEPTIONS:

1. Electrical receptacles serving a dedicated use.
2. A single outlet where all of the following conditions are met:
 - (a) the outlet is above a length of countertop that is uninterrupted by a sink or appliance; and
 - (b) at least one receptacle complying with Section 1002.9 is provided for that length of countertop; and
 - (c) all other receptacles provided for that length of countertop comply with Section 1002.9.
3. Floor electrical receptacles.
4. HVAC diffusers.
5. Controls mounted on range hoods if accessible redundant controls are provided.
6. Controls mounted on ceiling fans.

1002.10 Laundry Equipment. Washing machines and clothes dryers shall comply with Sections 1002.10.1 and 1002.10.2.

1002.10.1 Clear Floor or Ground Space. A clear floor space positioned for parallel approach shall be provided and shall be centered on the appliance.

1002.10.2 Operable Parts. All controls and operating mechanisms, including doors, lint screens, detergent and bleach compartments, shall comply with Section 309.

1002.11 Toilet and Bathing Facilities. All toilet and bathing facilities shall comply with Sections 1002.11.1 through 1002.11.7.

1002.11.1 Doors. Doors shall not swing into the clear floor or ground space or clearance for any fixture.

EXCEPTION: Where a clear floor or ground space complying with Section 305.3 is provided within the room, beyond the arc of the door swing.

1002.11.2 Overlap. Clear floor or ground spaces, clearances, and wheelchair turning spaces are permitted to overlap.

1002.11.3 Lavatory. Lavatories shall comply with Section 606.

EXCEPTION: Cabinetry shall be permitted to be added under the lavatory, provided such cabinetry can be removed without removal or replacement of the lavatory, and provided the finish floor extends under such cabinetry.

1002.11.4 Mirrors. Mirrors above lavatories shall have the bottom edge of the reflecting surface 40 inches (1015 mm) maximum above the floor or ground.

1002.11.5 Water Closet. Water closets shall comply with Sections 1002.11.5.1 through 1002.11.5.5.

1002.11.5.1 Location. The water closet shall be positioned with a wall to the rear

and to one side. The centerline of the water closet shall be 16 inches (405 mm) minimum and 18 inches (455 mm) maximum from the side wall.

1002.11.5.2 Clearance. Clearance around the water closet shall comply with Sections 1002.11.5.2.1 through 1002.11.5.2.3.

1002.11.5.2.1 Parallel Approach.

Where only a parallel approach is provided to the water closet, the clearance shall be 56 inches (1420 mm) minimum, measured perpendicular from the rear wall, and 48 inches (1220 mm) minimum, measured perpendicular from the side wall. A lavatory complying with Section 1002.11.3 shall be permitted on the rear wall, 18 inches (455 mm) minimum from the water closet centerline.

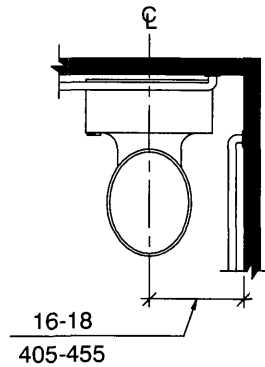
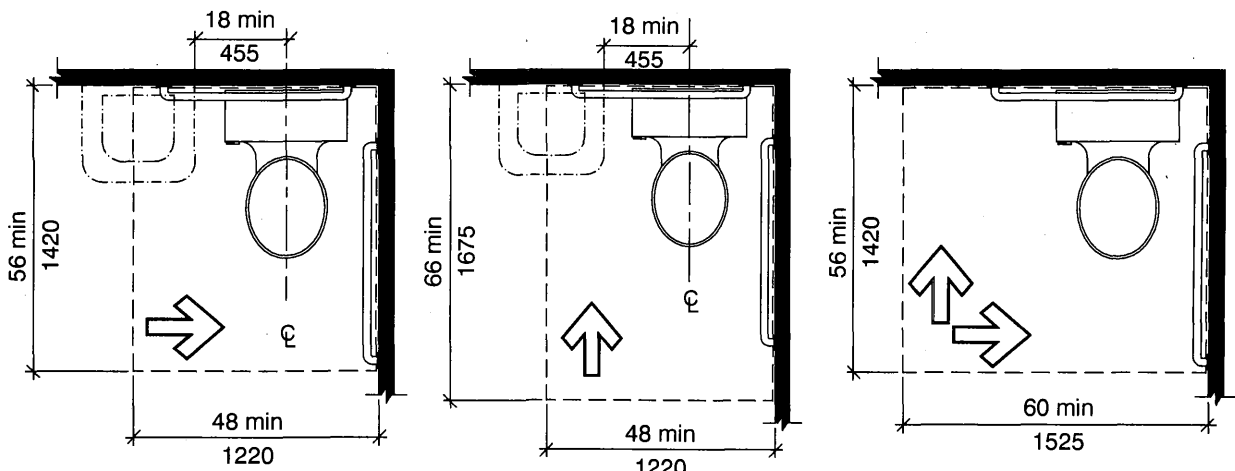

Fig. 1002.11.5.1
Location of Water Closet in Type A Dwelling Units



(a) Parallel Approach

(b) Forward Approach

(c) Parallel and Forward Approach

Fig. 1002.11.5.2
Water Closet Clearance in Type A Dwelling Units

1002.11.5.2.2 Forward Approach.

Where only a forward approach is provided to the water closet, the clearance shall be 66 inches (1675 mm) minimum, measured perpendicular from the rear wall, and 48 inches (1220 mm) minimum, measured perpendicular from the side wall. A lavatory complying with Section 1002.11.3 shall be permitted on the rear wall, 18 inches (455 mm) minimum from the water closet centerline.

1002.11.5.2.3 Parallel and Forward Approach.

Where both a parallel and a forward approach are provided to the water closet, the clearance shall be 56 inches (1420 mm) minimum, measured perpendicular from the rear wall, and 60 inches (1525 mm) minimum, measured perpendicular from the side wall. No fixtures or obstructions, other than the water closet, shall be within the clearance.

1002.11.5.3 Height. The top of the toilet seat shall be 15 inches (380 mm) minimum and 19 inches (485 mm) maximum above the floor or ground.

1002.11.5.4 Grab Bars. Grab bars complying with Section 604.5 shall be provided.

EXCEPTION: Where reinforcement has been provided in walls to permit the installation of such grab bars.

1002.11.5.5 Flush Controls. Hand-operated flush controls shall comply with Section 1002.9.

1002.11.6 Bathtub. Bathtubs shall comply with Section 607.

EXCEPTIONS:

1. The removable in-tub seat required by Section 607.3 is not required.
2. Grab bars are not required, provided reinforcement has been provided in walls to permit the installation of grab bars complying with Section 607.4.

1002.11.7 Shower. Showers shall comply with Section 608.

EXCEPTIONS:

1. A shower seat shall not be required in transfer-type showers, provided reinforcement has been provided in a wall to permit the installation of a seat complying with Section 610.3.

2. Grab bars are not required, provided reinforcement has been provided in walls to permit the installation of grab bars complying with Section 608.3.

1002.12 Kitchens. Kitchens shall comply with Sections 1002.12.1 through 1002.12.6.

1002.12.1 Clearance. Clearance complying with Sections 1002.12.1.1 and 1002.12.1.2 shall be provided.

1002.12.1.1 Galley. Clearance between all opposing base cabinets, counter tops, appliances, or walls within kitchen work areas shall be 40 inches (1015 mm) minimum.

1002.12.1.2 U-Shaped. In kitchens with counters, appliances, or cabinets on three contiguous sides, clearance between all opposing base cabinets, countertops, appliances, or walls within kitchen work areas shall be 60 inches (1525 mm) minimum.

1002.12.2 Clear Floor or Ground Space. Clear floor or ground spaces required by Sections 1002.12.3 through 1002.12.6 shall comply with Section 305.3.

1002.12.3 Work Surface. At least one 30 inches (760 mm) wide minimum section of counter shall provide a work surface that complies with Sections 1002.12.3.1 through 1002.12.3.3.

1002.12.3.1 Clear Floor or Ground Space. A clear floor space complying with Section 305.3 positioned for a forward approach shall be provided. The clear floor or ground space shall be centered on the work surface. The clear floor or ground space shall provide knee and toe clearance complying with Section 306.

EXCEPTION: Cabinetry shall be permitted to be added under the work surface, provided such cabinetry can be removed without removal or replacement of the work surface, and provided the finish floor extends under such cabinetry.

1002.12.3.2 Height. The work surface shall be 34 inches (865 mm) maximum above the floor or ground.

EXCEPTION: A counter that is adjustable to provide a work surface at variable heights 29 inches (735 mm) minimum and 36 inches (915 mm) maximum.

1002.12.3.3 Exposed Surfaces. There shall be no sharp or abrasive surfaces under the work surface counters.

1002.12.4 Sink. The sink and surrounding counter shall comply with Sections 1002.12.4.1

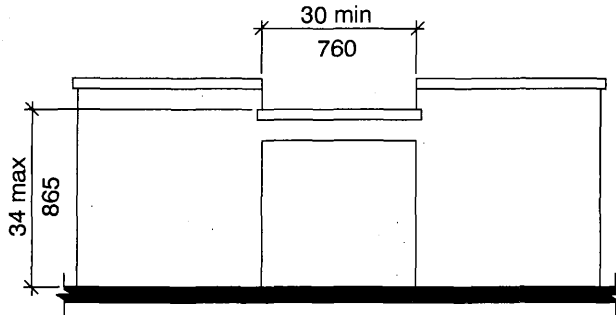

Fig. 1002.12.3
Work Surface in Kitchen

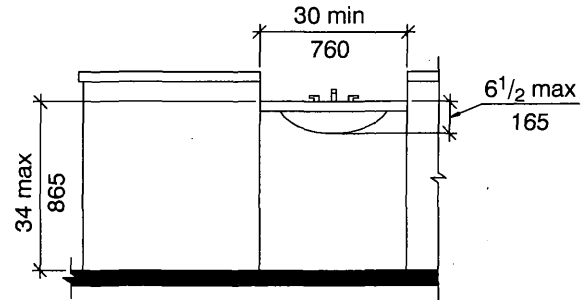

Fig. 1002.12.4
Kitchen Sink

through 1002.12.4.5. The width of the sink and surrounding counter complying with this section shall be 30 inches (760 mm) minimum.

1002.12.4.1 Clear Floor or Ground Space. A clear floor space positioned for a forward approach shall be provided. The clear floor or ground space shall be centered on the sink bowl. The clear floor or ground space shall provide knee and toe clearance complying with Section 306.

EXCEPTIONS:

1. Cabinetry shall be permitted to be added under the sink, provided such cabinetry can be removed without removal or replacement of the sink, and provided the finish floor extends under such cabinetry.
2. Adjustable-height sinks complying with Section 1002.12.4.3 are not required to provide knee clearance where placed at heights below 34 inches (865 mm).

1002.12.4.2 Height. The sink and surrounding counter shall be 34 inches (865 mm) maximum above the floor or ground, measured to the higher of the fixture rim or the counter surface.

EXCEPTION: Sink and counter that is adjustable to variable heights 29 inches (735 mm) minimum and 36 inches (915 mm) maximum, provided rough-in plumbing permits connections of supply and drain pipes for sinks mounted at the height of 29 inches (735 mm).

1002.12.4.3 Sink Bowl. The depth of a sink bowl shall be 6¹/₂ inches (165 mm) maximum. Multiple-compartment sinks shall have at least one compartment complying with this requirement.

1002.12.4.4 Faucets. Faucets shall comply with Section 309.

1002.12.4.5 Exposed Pipes and Surfaces. Water supply and drain pipes under sinks shall be insulated or otherwise configured to protect against contact. There shall be no sharp or abrasive surfaces under sinks.

1002.12.5 Kitchen Storage. Cabinets shall have a clear floor or ground space complying with Section 305.3, positioned for parallel or forward approach.

1002.12.6 Appliances. Where provided, kitchen appliances shall comply with Sections 1002.12.6.1 through 1002.12.6.7.

1002.12.6.1 Clear Floor or Ground Space. A clear floor or ground space complying with Section 305.3 positioned for parallel or forward approach shall be provided at each kitchen appliance. Clear floor or ground spaces shall be permitted to overlap.

1002.12.6.2 Operable Parts. All appliance controls shall comply with Section 309.

1002.12.6.3 Dishwasher. Clear floor or ground space shall be positioned adjacent to the dishwasher door. The dishwasher door in the open position shall not obstruct the clear floor or ground space for the dishwasher or the sink.

1002.12.6.4 Range or Cooktop. Where a forward approach clear floor or ground space is provided, the clear floor or ground space shall provide knee and toe clearance complying with Section 306. Where knee and toe space is provided, the underside of the range or cooktop shall be insulated or otherwise configured to prevent burns, abrasions, or electrical shock. The location

of controls shall not require reaching across burners.

1002.12.6.5 Oven. For side-opening ovens, the door latch side shall be next to a countertop. Ovens shall have controls on front panels, on either side of the door.

1002.12.6.6 Refrigerator/Freezer. Combination refrigerators and freezers shall have at least 50 percent of the freezer space 54 inches (1370 mm) maximum above the floor or ground. The clear floor or ground space shall be positioned for a parallel approach to the space dedicated to a refrigerator/freezer with the centerline of the clear floor or ground space offset 24 inches (610 mm) maximum from the centerline of the dedicated space.

1002.12.6.7 Trash Compactor. A clear floor or ground space positioned for parallel or forward approach shall be provided.

1002.13 Windows. Where operable windows are provided, at least one window in each sleeping, living, or dining space shall have operable parts complying with Section 1002.9. Each required operable window shall have operable parts complying with Section 1002.9.

1002.14 Storage Facilities. Where storage facilities are provided, they shall comply with Sections 1002.14.1 through 1002.14.3.

EXCEPTION: Kitchen cabinets shall comply with Section 1002.12.5.

1002.14.1 Clear Floor or Ground Space. A clear floor or ground space complying with Section 305.3, positioned for either parallel or forward approach, shall be provided at each storage facility.

1002.14.2 Height. A portion of the storage area of each storage facility shall accommodate a forward reach or side reach complying with Section 308.

1002.14.3 Operable Parts. Operable parts on storage facilities shall comply with Section 309.

1003 Type B Dwelling Units

1003.1 General. Type B dwelling units shall comply with Section 1003.

1003.2 Primary Entrance. The accessible primary entrance shall be on an accessible route from public and common areas. The primary entrance shall not be to a bedroom.

1003.3 Accessible Route. Accessible routes within Type B dwelling units shall comply with Sections 1003.3.1 and 1003.3.2.

EXCEPTION: One of the following is not required to be on an accessible route:

1. A raised floor area in a portion of a living, dining, or sleeping room; or
2. A sunken floor area in a portion of a living, dining, or sleeping room; or
3. A mezzanine that does not have plumbing fixtures or an enclosed habitable space.

1003.3.1 Location. At least one accessible route shall connect all spaces and elements which are a part of the dwelling unit. Where only one accessible route is provided, it shall not pass through restrooms, closets, or similar spaces.

1003.3.2 Components. Accessible routes shall consist of one or more of the following elements: walking surfaces with a slope not steeper than 1:20, doorways, ramps, elevators, and wheelchair (platform) lifts.

1003.4 Walking Surfaces. Walking surfaces that are part of an accessible route shall comply with Sections 1003.4.1 and 1003.4.2.

1003.4.1 Width. Clear width of an accessible route shall comply with Section 403.5.

1003.4.2 Changes in Level. Changes in level shall comply with Section 303.

EXCEPTION: Where exterior deck, patio or balcony surface materials are impervious, the finished exterior impervious surface shall be 4 inches (102 mm) maximum below the finished floor level of the adjacent interior spaces of the dwelling unit.

1003.5 Doors and Doorways. Doors and doorways shall comply with Sections 1003.5.1 and 1003.5.2.

1003.5.1 Primary Entrance Door. The primary entrance door to the dwelling unit shall comply with Section 404.

EXCEPTION: Maneuvering clearances required by Section 404.2.4 shall not be required on the dwelling unit side of the primary entrance door.

1003.5.2 User Passage Doorways. Doorways intended for user passage shall comply with Sections 1003.5.2.1 through 1003.5.2.4.

1003.5.2.1 Clear Width. Doorways shall have a clear opening of 31³/₄ inches (810 mm) minimum. Clear opening of swinging

doors shall be measured between the face of the door and stop, with the door open 90 degrees.

1003.5.2.2 Thresholds. Thresholds shall comply with Section 303.

EXCEPTION: Thresholds at exterior sliding doors shall be permitted to be $\frac{3}{4}$ inch (19 mm) high maximum provided they are beveled with a slope not steeper than 1:2.

1003.5.2.3 Automatic Doors. Automatic doors shall comply with Section 404.3.

1003.5.2.4 Double Leaf Doorways. Where an inactive leaf with operable parts more than 48 inches (1220 mm) above the floor or ground is provided, the active leaf shall provide the clearance required by Section 1003.5.2.1.

1003.6 Ramps. Ramps shall comply with Section 405.

1003.7 Private Residence Elevators. Elevators shall comply with Section 1002.7.

EXCEPTION: Elevators complying with Section 407.

1003.8 Wheelchair (Platform) Lifts. Wheelchair (platform) lifts shall comply with ASME/ANSI A17.1 and with Sections 305 and 309.

1003.9 Operable Parts. Lighting controls, electrical receptacles, environmental controls, and user controls for security or intercom systems shall comply with Sections 309.2 and 309.3.

EXCEPTIONS:

1. Electrical receptacles serving a dedicated use.
2. Appliance mounted controls or switches.
3. A single outlet where all of the following conditions are met:
 - (a) the outlet is above a length of countertop that is uninterrupted by a sink or appliance; and
 - (b) at least one receptacle complying with Section 1003.9 is provided for that length of countertop; and
 - (c) all other receptacles provided for that length of countertop comply with Section 1003.9.
4. Floor electrical receptacles.
5. Plumbing fixture controls.
6. HVAC diffusers.
7. Ceiling fan mounted controls.

1003.10 Laundry Equipment. Washing machines and clothes dryers shall comply with Section 1003.10.1.

1003.10.1 Clear Floor or Ground Space. A clear floor or ground space complying with Section 305.3, positioned for parallel approach and centered on the appliance shall be provided.

1003.11 Toilet and Bathing Fixtures. Toilet and bathing fixtures shall comply with Sections 1003.11.1 through 1003.11.3.

EXCEPTION: Fixtures on levels not required to be accessible.

1003.11.1 Clear Floor or Ground Space. Clear floor or ground space required by Section 1003.11.3.1 or 1003.11.3.2 shall comply with Section 305.3 and Sections 1003.11.1.1 through 1003.11.1.3.

1003.11.1.1 Doors. Doors shall not swing into the clear floor or ground space for any fixture.

EXCEPTION: Where a clear floor or ground space complying with Section 305.3, excluding knee and toe clearances under elements, is provided within the room, beyond the arc of the door swing.

1003.11.1.2 Knee and Toe Clearance. Clear floor or ground space shall be permitted to include knee and toe clearances complying with Section 306.

1003.11.1.3 Overlap. Clear floor or ground spaces shall be permitted to overlap.

1003.11.2 Grab Bar Reinforcement. Reinforcement shall be provided for future installation of grab bars and shower seats at water closets, bathtubs, and shower compartments. Where walls are to permit installation of grab bars and seats complying with Section 604.5, 607.4, or 610, reinforcement shall be provided for future installation of grab bars meeting those requirements.

EXCEPTION: Reinforcement is not required in a room containing only a lavatory and a water closet, provided that the room does not contain the only lavatory or water closet on the accessible level of the dwelling unit.

1003.11.3 Bathroom Fixtures. Bathroom fixtures shall comply with either Section 1003.11.3.1 (Option A) or Section 1003.11.3.2 (Option B).

1003.11.3.1 Option A. Each fixture provided shall comply with Sections 1003.11.3.1.1 through 1003.11.3.1.3.

EXCEPTION: A lavatory and a water closet in a room containing only a lavatory and water closet, provided that the room does not contain the only lavatory or water closet on the accessible level of the dwelling unit.

1003.11.3.1.1 Lavatory. A clear floor or ground space complying with Section 305.3, positioned for a parallel approach and centered on the lavatory shall be provided.

EXCEPTIONS:

1. A lavatory complying with Section 606.
2. Cabinetry shall be permitted to be added under the lavatory, provided such cabinetry can be removed without removal or replacement of the lavatory, and provided the finish floor extends under such cabinetry.

1003.11.3.1.2 Water Closet. The lateral distance from the centerline of the water closet to a bathtub, or lavatory shall be 18 inches (455 mm) minimum on one side and 15 inches (380 mm) minimum on the other side. Where the water closet is adjacent to the wall the lateral distance from the centerline of the water closet to the wall shall be 18 inches (455 mm) and 15 inches (380 mm) minimum to a lavatory or bathtub. The water closet shall be positioned to allow for future installation of a grab bar on the side with 18 inches (455 mm) clearance. Clearance areas around the water closet shall comply with Section 1003.11.3.1.2.1, 1003.11.3.1.2.2, or 1003.11.3.1.2.3.

1003.11.3.1.2.1 Parallel Approach. 56 inches (1420 mm) minimum shall be provided measured from the wall behind the water closet. 48 inches (1220 mm) minimum shall be provided measured from a point 18 inches (455 mm) from the centerline of the water closet on the side designated for future installation of grab bars. Vanities or lavatories on the wall behind the water closet are permitted to overlap the clear floor or ground space.

1003.11.3.1.2.2 Forward Approach. 66 inches (1675 mm)

minimum shall be provided measured from the wall behind the water closet. 48 inches (1220 mm) minimum shall be provided measured from a point 18 inches (455 mm) from the centerline of the water closet on the side designated for future installation of grab bars. Vanities or lavatories on the wall behind the water closet are permitted to overlap the clear floor or ground space.

1003.11.3.1.2.3 Parallel or Forward Approach. 56 inches (1420 mm) minimum shall be provided measured from the wall behind the water closet. 42 inches (1065 mm) shall be provided measured from the centerline of the water closet.

1003.11.3.1.3 Bathing Facilities.

Where a bathtub or shower compartment is provided it shall conform with Section 1003.11.3.1.3.1, 1003.11.3.1.3.2, or 1003.11.3.1.3.3.

1003.11.3.1.3.1 Parallel Approach Bathtubs. Clearance in front of bathtubs with a parallel approach shall be 30 inches (760 mm) wide minimum by 60 inches (1525 mm) long minimum. A lavatory shall be permitted at the foot end of the bathtub if a 30 inch (760 mm) wide minimum by 48 inch (1220 mm) long minimum clearance in front of the bathtub is provided.

EXCEPTION: Lavatories complying with Section 606 shall be permitted in the clearance.

1003.11.3.1.3.2 Forward Approach Bathtubs. Clearance in front of bathtubs with a forward approach shall be 48 inches (1220 mm) wide minimum by 60 inches (1525 mm) long minimum. A water closet shall be permitted in the clearance at the foot end of the bathtub.

1003.11.3.1.3.3 Shower Compartment. If a shower compartment is the only bathing facility, the shower compartment shall be 36 inches (915 mm) minimum by 36 inches (915 mm) minimum. Reinforcing for shower seat is not re-

quired in shower compartments larger than 36 inches (915 mm) by 36 inches (915 mm). Clearance of 30 inches (760 mm) wide minimum, measured from the face of the shower compartment, by 48 inches (1220 mm) deep minimum, measured from the shower head wall shall be provided.

1003.11.3.2 Option B. One of each type of fixture provided shall comply with Sections 1003.11.3.2.1 through 1003.11.3.2.3. The accessible fixtures shall be in a single toilet/bathing area, such that travel between fixtures does not require travel through other parts of the dwelling unit.

1003.11.3.2.1 Lavatory. Lavatories shall comply with Sections 1003.11.3.2.1.1 through 1003.11.3.2.1.3.

1003.11.3.2.1.1 Clear Floor or Ground Space. A clear floor or ground space complying with Section 305.3, positioned for a parallel approach shall be provided.

EXCEPTION: A lavatory complying with Section 606.

1003.11.3.2.1.2 Position. The centerline of the lavatory shall align with the centerline of the clear floor or ground space.

1003.11.3.2.1.3 Height. The front of the lavatory shall be 34 inches (865 mm) maximum above the floor or ground, measured to the higher of the fixture rim or counter surface.

1003.11.3.2.2 Water Closet. The water closet shall comply with Section 1003.11.3.1.2.

1003.11.3.2.3 Bathing Facilities. Where either a bathtub or shower compartment is provided, it shall conform with Section 1003.11.3.2.3.1 or 1003.11.3.2.3.2.

1003.11.3.2.3.1 Bathtub. Clearance in front of bathtubs shall be 30 inches (760 mm) wide minimum by 48 inches (1220 mm) long minimum measured from the foot end of the bathtub.

1003.11.3.2.3.2 Shower Compartment. If a shower compartment is the only bathing facility the shower compartment shall have minimum dimensions of 36 inches (916 mm) minimum by 36 inches (915 mm) minimum. Reinforcing for shower seat is not required in shower compartments larger than 36 inches (915 mm) by 36 inches (915 mm). Clearance 30 inches (760 mm) minimum, measured from the face of the shower compartment, by 48 inches (1220 mm) minimum, measured from the shower head wall shall be provided.

1003.12 Kitchens. Kitchens shall comply with Sections 1003.12.1 and 1003.12.2.

1003.12.1 Clearance. Clearance complying with Sections 1003.12.1.1 and 1003.12.1.2 shall be provided.

1003.12.1.1 Galley. Clearance between all opposing base cabinets, counter tops, appliances, or walls within kitchen work areas shall be 40 inches (1015 mm) minimum.

1003.12.1.2 U-Shaped. In kitchens with counters, appliances, or cabinets on three contiguous sides, clearance between all opposing base cabinets, countertops, appliances, or walls within kitchen work areas shall be 60 inches (1525 mm) minimum.

1003.12.2 Clear Floor or Ground Space. Clear floor or ground space at appliances shall comply with Section 305.3 and Sections 1003.12.2.1 through 1003.12.2.6.

1003.12.2.1 Sink. The sink shall comply with Sections 1003.12.2.1.1 and 1003.12.2.1.2.

1003.12.2.1.1 Approach. Clear floor or ground space shall be positioned for a parallel approach.

EXCEPTION: Sink complying with Section 606.

1003.12.2.1.2 Position. The centerline of the sink shall align with the centerline of the clear floor or ground space.

1003.12.2.2 Dishwasher. Clear floor or ground space shall be positioned for parallel or forward approach. Clear floor or ground space shall be positioned beyond the swing of the dishwasher door.

1003.12.2.3 Range or Cooktop. Clear floor or ground space shall be positioned for parallel approach.

EXCEPTION: Where a forward approach clear floor or ground space is provided, the clear floor or ground space shall provide knee and toe clearance complying with Section 306. Where knee and toe space is provided, the underside of the range or cooktop shall be insulated or otherwise configured to prevent burns, abrasions, or electrical shock.

1003.12.2.4 Oven. Clear floor or ground space shall be positioned for parallel or forward approach.

1003.12.2.5 Refrigerator/Freezer. Clear floor or ground space shall be positioned for parallel or forward approach.

1003.12.2.6 Trash Compactor. Clear floor or ground space shall be positioned for parallel or forward approach.

1004 Dwelling Units with Accessible Communication Features

1004.1 General. Dwelling units required to have accessible communication features shall comply with Section 1004.

1004.2 Dwelling Unit Smoke Detection. Where provided, dwelling unit smoke detection shall include audible notification complying with NFPA 72.

1004.3 Building Fire Alarm System. Where a building fire alarm system is provided, the system wiring shall be extended to a point within the dwelling unit in the vicinity of the dwelling unit smoke detection system.

1004.4 Visible Notification Appliances. Visible notification appliances, where provided within the dwelling unit as part of the dwelling unit smoke detection system or the building fire alarm system, shall comply with Sections 1004.4.1 through 1004.4.4.

1004.4.1 Appliance. Visible notification appliance shall comply with NFPA 72.

1004.4.2 Activation. All visible notification appliances provided within the dwelling unit for smoke detection notification shall be activated upon smoke detection. All visible notification appliances provided within the dwelling unit for building fire alarm notification shall be activated

upon activation of the building fire alarm in the portion of the building containing the dwelling unit.

1004.4.3 Interconnection. The same visible notification appliances shall be permitted to provide notification of dwelling unit smoke detection and building fire alarm activation.

1004.4.4 Prohibited Use. Visible notification appliances used to indicate dwelling unit smoke detection or building fire alarm activation shall not be used for any other purpose within the dwelling unit.

1004.5 Dwelling Unit Primary Entrance. Communication features shall be provided at the dwelling unit primary entrance complying with Sections 1004.5.1 and 1004.5.2.

1004.5.1 Notification. A hard-wired electric doorbell shall be provided. A button or switch shall be provided on the public side of the dwelling unit primary entrance. Activation of the button or switch shall initiate an audible tone within the dwelling unit.

1004.5.2 Identification. A means for visually identifying a visitor without opening the dwelling unit entry door shall be provided. Peepholes, where used, shall provide a minimum 180 degree range of view.

1004.6 Site, Building, or Floor Entrance. Where a system permitting voice communication between a visitor and the occupant of the dwelling unit is provided at a location other than the dwelling unit entry door, the system shall comply with Sections 1004.6.1 and 1004.6.2.

1004.6.1 Public or Common-Use Interface. The public or common-use system interface shall include the capability of supporting voice and TTY communication with the dwelling unit interface.

1004.6.2 Dwelling Unit Interface. The dwelling unit system interface shall include a telephone jack capable of supporting voice and TTY communication with the public or common-use system interface.

1004.7 Closed-Circuit Communication Systems. Where a closed-circuit communication system is provided, the public or common-use system interface shall comply with Section 1004.6.1, and the dwelling unit system interface in units required to have accessible communication features shall comply with Section 1004.6.2.

ANSI A117.1

1992 – 1998 CROSS REFERENCE

ANSI A117.1
1992 – 1998 CROSS REFERENCE

CABO/ANSI A117.1-1992	ICC/ANSI A117.1-1998
1. Purpose and Application	Chapter 1. Application and Administration
1.1 Purpose	101 Purpose
1.2 Application	101.1 Applicability
2. Recommendations to Adopting Authorities	-----
2.1 Administration	102 Administration
2.2 Number of Spaces and Elements	Chapter 2. Scoping
2.3 Remodeling	-----
2.4 Review Procedures	-----
3. Graphics, Dimensions, Referenced Standards, and Definitions	-----
3.1 Graphic Conventions	-----
3.2 Dimensions	104 Dimensions
3.3 Referenced American National Standards	105 Referenced American National Standards
3.4 Definitions	106 Definitions
4. Accessible Elements and Spaces	-----
4.1 Basic Components	-----
4.2 Space Allowances and Reach Ranges	304 Wheelchair Turning Space 305 Clear Floor or Ground Space for Wheelchairs 306 Knee and Toe Clearance 308 Reach Ranges
4.3 Accessible Route	402 Accessible Routes 403 Walking Surfaces 505 Handrails
4.4 Protruding Objects	307 Protruding Objects
4.5 Ground and Floor Surfaces	302 Ground and Floor Surfaces 303 Changes in Level
4.6 Parking Spaces and Passenger Loading Zones	502 Parking Spaces 503 Passenger Loading Zones
4.7 Curb Ramps	406 Curb Ramps
4.8 Ramps	405 Ramps
4.9 Stairs	504 Stairways
4.10 Elevators	407 Elevators
4.11 Wheelchair Lifts	408 Wheelchair (Platform) Lifts
4.12 Windows	506 Windows
4.13 Doors	404 Doors
4.14 Entrances	-----
4.15 Drinking Fountains and Water Coolers	602 Drinking Fountains and Water Coolers
4.16 Toilet, Bathing, Dressing and Shower Rooms and Bathing Facilities	603 Toilet and Bathing Rooms 803 Dressing, Fitting, and Locker Rooms

(Continued)

CABO/ANSI A117.1-1992	ICC/ANSI A117.1-1998
4.17 Water Closets	604 Water Closets and Toilet Compartments
4.18 Toilet Stalls	
4.19 Urinals	605 Urinals
4.20 Lavatories and Sinks	606 Lavatories and Sinks
4.21 Bathtubs	607 Bathtubs
4.22 Shower Stalls	608 Shower Compartments
4.23 Storage	905 Storage
4.24 Grab Bars, and Tub and Shower Seats	609 Grab Bars 610 Seats
4.25 Operable Parts of Equipment and Appliances	309 Operable Parts
4.26 Alarms	702 Alarms
4.27 Detectable Warnings – Standardization	705 Detectable Warnings
4.28 Signage	703 Signs
4.29 Telephones	704 Telephones
4.30 Automatic Teller Machines	707 Automatic Teller Machines
4.31 Seating, Tables, Work Services and Service Counters	902 Seating at Tables, Counters and Work Surfaces 903 Benches 904 Sales and Service Counters
4.32 Auditorium and Assembly Areas	706 Assistive Listening Systems 802 Auditorium and Assembly Areas
4.33 Dwelling Units	Chapter 10 Dwelling Units 1002 Type A Dwelling Units 1003 Type B Dwelling Units 1004 Dwelling Units with Accessible Communication Features

<i>New in 1998 edition:</i>
103 Compliance Alternatives
507 Bus Stop Pads
611 Laundry Equipment <i>(previously limited to dwelling unit section)</i>
804 Kitchens <i>(previously limited to dwelling unit section)</i>

Errata to ICC/ANSI A117.1-1998, First Printing

1. Page 15, Table 404.2.4.1: In footnote 2, change the metric equivalent to 305 mm
2. Page 17, Section 404.2.4.4: Typo in title (Recessed)
3. Page 23: Revise Figure 407.2.4 as follows:

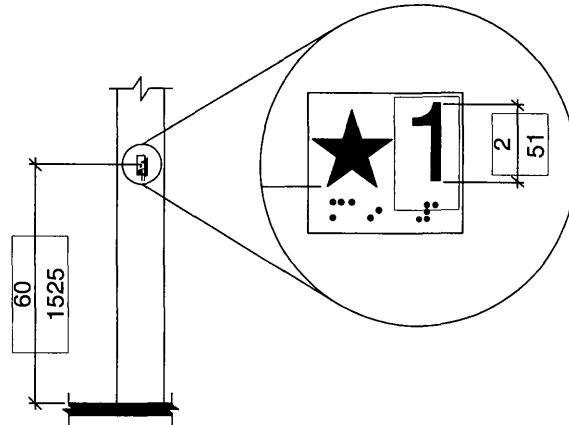

4. Page 27: Revise cross reference in Section 407.3: "...shall also comply with 407.3.1 through 407.3.5 407.3.6 and..."
5. Page 28: Revise Figure 407.3.5 as follows:

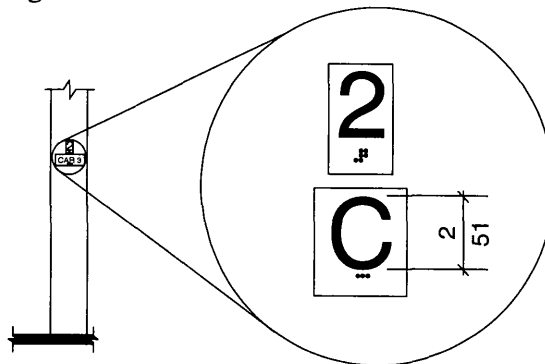

6. Page 29: Revise cross-reference in 407.4.9 as follows: "...shall comply with Sections 407.4.9.1 through 407.4.9.3 407.4.9.4."
7. Page 42: Revise Figure 604.8.1.4(a) by changing "max" to "min" in both places.
8. Page 48: Change metric equivalent for 4.8 inches to 120 (not 160).
9. Page 48: Revise cross reference in 609.2 as follows: "...equivalent graspability complying with Section ~~505.7.1~~ 609.2.1."
10. Page 48: Revise Figure 609.2(a) to show the range of the grab bar diameter as 1¼ – 2 (not 1¼ - 1½)
11. Page 72: Revise cross reference in 1002.11.5.5 as follows: "...shall comply with Section ~~1002.8~~ 1002.9."
12. Page 72: Section 1002.12.3 – Typo (Sections)

Errata to ICC/ANSI A117.1-1998, Second Printing

1. Page 1: Change in Section 101, second paragraph: "...Federal Fair Housing ~~Amendments~~ Act Accessibility Guidelines."
2. Page 51: Figure 702.3.3.1: Add an "(a)" at the symbol indicated at 80-96 inches above the floor. Add a "(b)" for the symbol indicated at 4-12 inches below the ceiling.
3. Page 77: Change Section "~~1003.11.1.2~~ (right-hand column under 1003.12.1.1) to "1003.12.1.2".
4. Page 73: In the illustrations at the top of the page, change the "34 min" to "34 max".

Errata to ICC/ANSI A117.1-1998, Third Printing

1. Correct and coordinate all metric dimensions.
2. Page 7: Change in Fig. 302.2: Relocate line indicating bottom of carpet pile.
3. Page 10: Change Fig. 307.3(a): Add dimension for 80 inch height of protrusion limit.
4. Page 12: Change Fig. 308.3.1: Add dimension for 15 inch minimum height of low side unobstructed side reach.
5. Page 12: Change Fig. 308.3.2(a) & (b): Add dimension for 34 inch maximum height of obstruction.
6. Page 15: Change Section 404.2.4 Exception: Delete text “(...latch side of door provided...)”
7. Page 22: Change Fig. 406.12(a): Add dimension for 32/36 inch minimum width of cut-through per Section 403.5.
8. Page 22: Change Fig. 406.12(b): Relocate indicators for approach to curb ramp flared sides.
9. Page 26: Change Table 407.2.11.2: The tactile symbols for the alarm and the phone to be solid black.
10. Page 26: Change Table 407.2.11.2: Correct braille pattern for Phone in the forth column, forth cell (dots 1,3,5, not 1,2,5) .
11. Page 26: Change Table 407.2.11.2: Align braille message cells and dot patterns.
12. Page 47: Change Section 608.5: Change “120°F” to “120 degrees F (49 degrees C)”.
13. Page 49: Change Section 609.8: Change “lb” to “pounds”.
14. Page 50: Change Section 610.4: Change “pound” to “pounds”.
15. Page 52: Change Section 702.3.4.1(3): Change “80 feet by 80 feet (24 m by 24 m)” to “80 feet (24 m) by 80 feet (24 m)”.
16. Page 76: Change Section 1003.11.3.1.2.1: Change “~~Fifty-six~~” to “56”, and “~~Forty-eight~~” to “48”.
17. Page 76: Change Section 1003.11.3.1.2.2: Change “~~Sixty-six~~” to “66”, and “~~Forty-eight~~” to “48”.
18. Page 76: Change Section 1003.11.3.1.2.3: Change “~~Fifty-six~~” to “56”, and “~~Forty-two~~” to “42”.
19. Page 76: Change Section 1003.11.3.1.3.1: Delete text “...by 48 inch (760 mm by 1220 mm)”.